

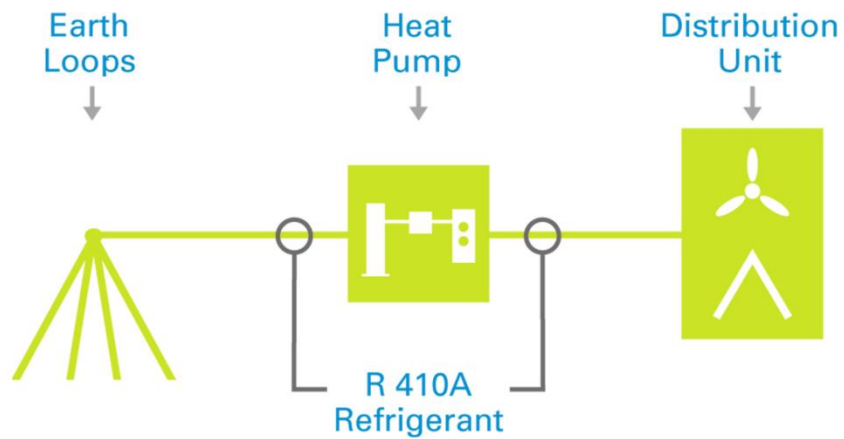

EARTHLINKED
TECHNOLOGIES



New Installer Training

Southern U.S.

Welcome to EarthLinked Technologies!

Thank you for making the choice to learn more about our company and technology. Our mission is to create products and services focused on simple, efficient and effective ways to make life easier for people and planet. We have the most powerfully efficient method of space heating and cooling available today.

This training is meant to be a launching point of our ongoing relationship. Our team is here to serve you before, during and after the installation. Beyond this technical training, we have tools and programs available to help you grow your business through sales, marketing and advertising programs.

I look forward to our future together!

Warm Regards,

Jeff Miller

President, EarthLinked Technologies, Inc.

jmiller@earthlinked.com

863-701-0096

This supplement is for training purposes only and does not replace the Installation or other technical manuals as provided by EarthLinked Technologies for the purpose of specifying, installing and maintaining EarthLinked® equipment.

Table of Contents

- Training Package, Scope and Outline 4
- Vocabulary 6
- Dealer Benefits 7
- System Schematics 9
- System Sizing Procedure..... 11
- Ordering and Warranty process..... 18
- Key Corporate Contacts 19
- Earth Loop Review Questions 20
- Space Heating & Cooling Review Questions 21
- Dealer-trainee Information Form 22
- EarthLinked Dealer-trainee Exam 23
- Training Assessment Form..... 25

Training Package, Scope and Outline

Training Package (<https://earthlinked.com/dealers/training/>)

- ✔ Training Booklet
- ✔ Supplementary Slides: Product Line Presentation, 10 myths about DX
- ✔ Tech Tip Videos
- ✔ Advanced training available: Hydronic training, Troubleshooting training

Scope of the New Installer Training

- ✔ Forced air systems: Prime PSC and PSD, Classic SC and SD
- ✔ All Earth Loop configurations
- ✔ 8-hour Presentation Outline:
 - The EarthLinked System
 - Product Line Overview
 - How It Works
 - System Selection and Sizing
 - Installation
 - System Charging & Start-Up
 - Q & A
 - Exam

Product Series	Comp. Unit	Air Htg.	Air Clg.	Hydronic Htg.	Hydronic Clg.	Domestic Water Htg.	Energy Star
PRIME Series (two-speed)	PSC	✔	✔				✔
	PSD	✔	✔			✔	✔
	PSDH	✔	✔	✔		✔	✔
CLASSIC Series (single speed)	SC	✔	✔				✔
	SD	✔	✔			✔	✔
	SDH	✔	✔	✔		✔	✔
	SCW			✔	✔		
	SCWD			✔	✔	✔	

Product Line Description and Application (R410-A)

NEW INSTALLER TRAINING OUTLINE

Pre-training Quiz

Test your basic HVAC
knowledge

STEP
01



STEP
02

On-site Training

Duration: 8-hours

Post-training Exam

Receive a Certificate

STEP
03



STEP
04

Become a Dealer

Sign the Dealer Agreement

Start Selling

Welcome aboard!

STEP
05



Vocabulary

- 🌱 ETI: EarthLinked Technologies, Inc.

Internal Components

- 🌱 EDM: EarthLinked Diagnostics & Monitoring system
- 🌱 ACC: Active Charge Control
- 🌱 LFC: Liquid Flow Control
- 🌱 CAV: Cooling Assist Valve
- 🌱 HRM: Heat Recovery Module (aka Desuperheater, Hot Water Assist)
- 🌱 Nano-PLC: Programmed Logic Controller
- 🌱 EPS: Earth Loop Cathodic Protection System

External Components

- 🌱 HCM: Hybrid Cooling Module
- 🌱 HWM: Hydronic Water Module
- 🌱 Loop models
 - Vertical loops: V1, V1.5 and V2
 - Diagonal loops: D1, D1.5 and D2
 - Horizontal loops: H1B
- 🌱 Compressor models
 - Prime Series: PSC, PSD, PSDH
 - Classic Series: SC, SD, SDH, SCW and SCWD
- 🌱 Air Handler models
 - Fixed-speed: AVS
 - Variable speed: AVV
 - High-velocity: HVA

Dealer Benefits

EarthLinked is committed to providing our dealers with superior products and service to better assure desired profit margins, higher customer satisfaction & loyalty, and positive word-of-mouth for both EarthLinked and our dealers.

Profitability

- ✔ Enhanced profit potential over conventional ASHP
- ✔ Exclusive trade areas
- ✔ Easier to sell with competitive differentiation
- ✔ Highest customer satisfaction and qualified referral rates

Installation

- ✔ No learning a whole new technology, or expensive new equipment
- ✔ Enhanced safety by eliminating combustion and carbon monoxide exposure
- ✔ Fast and easy installations with pre-assembled earth loops and components
- ✔ Most compact footprint – installs in places other geothermal systems will not fit thanks to the smallest header-pit in the industry

Maintenance

- ✔ Highest manufacturing quality – made in the USA, hand-assembled, and processed through numerous check-points for quality assurance
- ✔ Proven reliability – over 30 years of superior operation with thousands of systems installed across 18 countries, totaling over 100,000,000 hours of service
- ✔ Simple design – systems are designed for easy access to all major components.
- ✔ Real-time remote diagnostics and monitoring is standard on all EarthLinked Prime series units – 24/7 proactive customer service eliminates nuisance calls with the EDM system

Support

- ✔ Tiered 360 support system features more than 30-years experience and unlimited one-on-one access to: area managers, engineering team, sales support, marketing specialists, leadership and more
- ✔ 1-day advanced training programs customized for individual skill levels
- ✔ A database of technical literature organized from a dealer's perspective
- ✔ Innovative advertising programs include: aggressive lead generation, public relations assistance, personal marketing consultations, customizable marketing literature, social networking support and more

Product

- ✔ AHRI tested, Energy Star certified*, and included in the IGSHPA standards (2016 Edition)
- ✔ Responsive delivery – an extensive warehouse inventory stocked for rapid delivery of complete systems, as well as warranty and accessory parts
- ✔ Environmentally-friendly systems omit less CO₂ and create safer environments for people and planet
- ✔ EarthLinked stands behind their products 100% to offer dealers peace-of-mind
- ✔ Perfect balance of power and efficiency
- ✔ Simple: a standard heat/cool unit, one-step geothermal heat exchange

*Hydronic systems not included

System Schematics

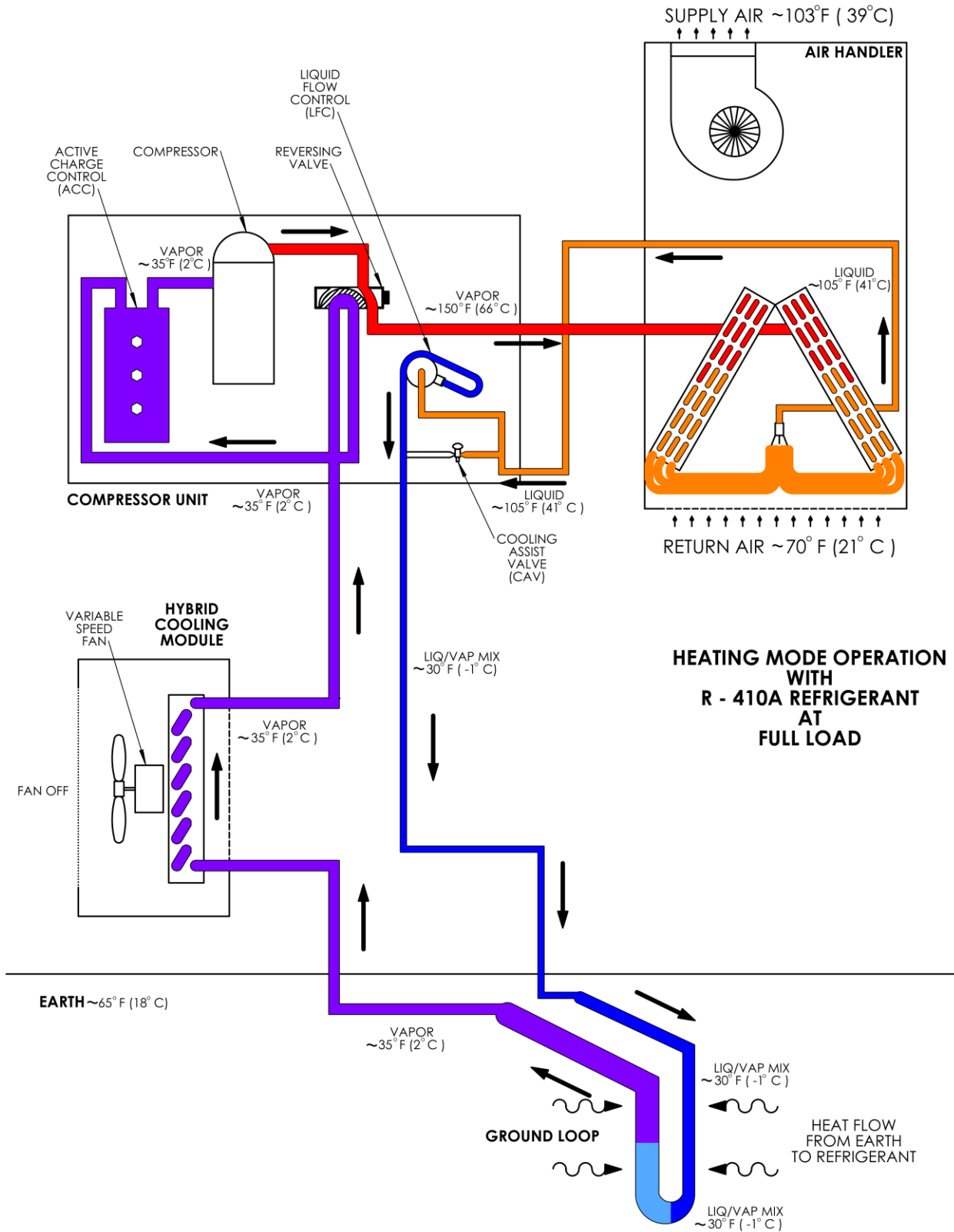

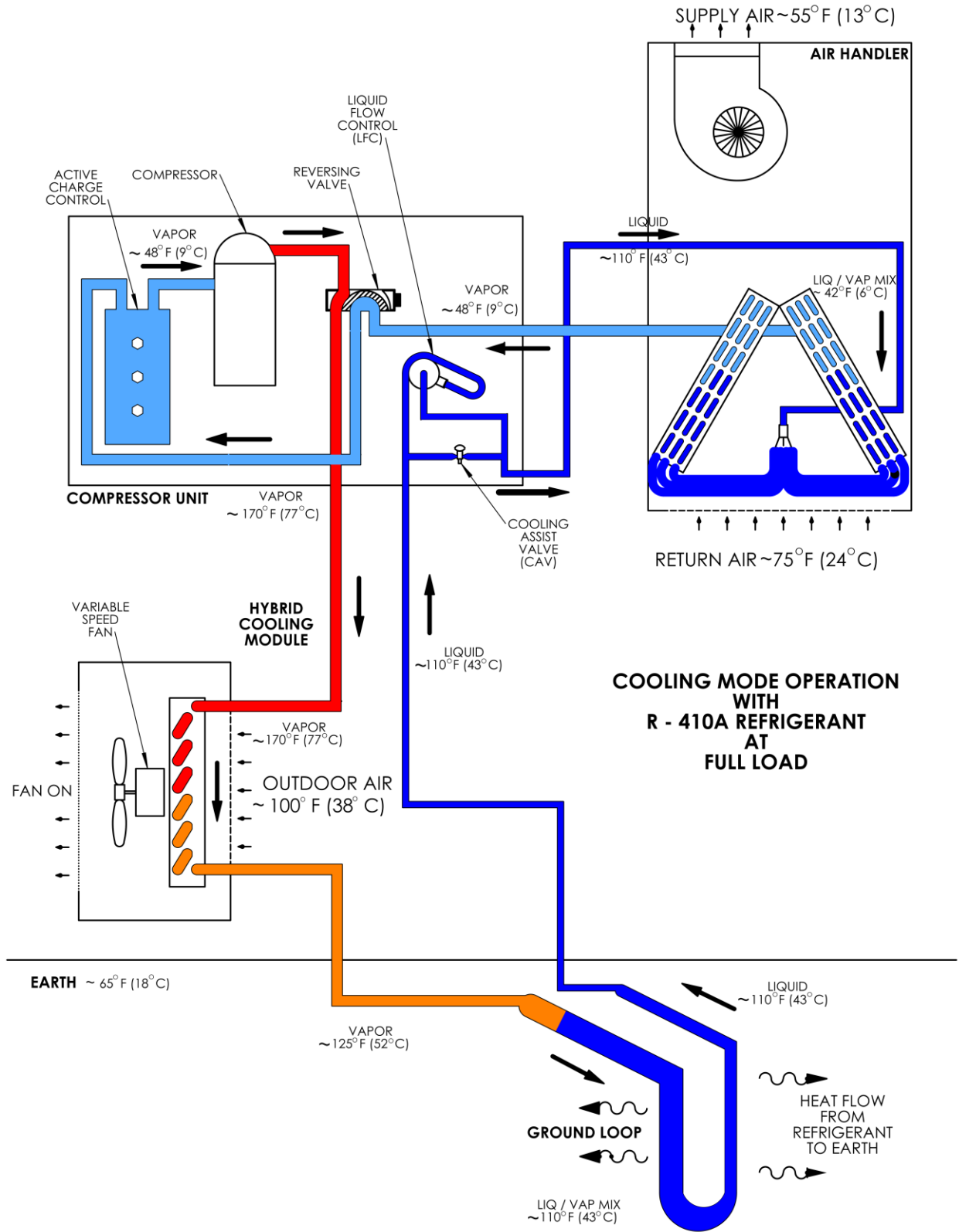

System Sizing Procedure

Note: Proper sizing is critical to the performance, efficiency and reliability of systems.

Notwithstanding the information contained in the most current edition of the appropriate ETI manuals, following are the steps to be used in selecting an ETI system:

STEP 1: Determine heating and cooling requirements of the structure, based on the ACCA Manual J (latest edition) procedure using the ASHRAE 99.6% heating design temperature and the 0.4% cooling design temperature.

STEP 2: Determine application.

- a. Discuss with customer range of applications available: forced air heating and cooling, hydronic water heating and chilling combinations, etc
- b. Determine electric service and modifications and/or upgrades based on power requirements
- c. Determine duct work modifications based on 400 CFM/nominal ton
- d. Discuss necessity and advantages of HCM when installation is required
- e. Discuss buyer incentives provided by government for energy efficient products
- f. Obtain customer approval of proposed optimal earth loop configuration based on available land area and/or geology.

STEP 3a: Use EarthLinked Technologies Geothermal Design Software⁽¹⁾ to determine the best equipment choice to deliver required heating and/or cooling. This software also helps you quickly prepare an economic analysis and present a profession report to your customers.

STEP 3b: Use SYSTEM SIZING WORKSHEET to determine best choice to deliver required heating and/or cooling (see example page 13 to 17). Choices include:

- g. Forced air - Heating dominant load.
- h. Forced air - Cooling dominant load.
- i. Hydronic water - Heating dominant load
- j. Chilled water - Cooling dominant load.

STEP 4: Finalize the list of equipment required for the project.

STEP 5: Calculate equipment total cost and order your system using EarthLinked's Online Ordering Tool⁽²⁾.

⁽¹⁾ EarthLinked Technologies Geothermal Design Software is a customized version of LoopLink offered by EarthLinked Technologies through Geo-Connections, accessible at <https://eti.looplinkrlc.com/>. This web-based, subscription-based design software will enable you to design multiple zone, multiple heat pump geothermal systems faster and more accurately than ever before.

⁽²⁾ Accessible at <https://earthlinked.com/dealers/new-order/>

Page 13 to 17 you will find an example of sizing using our SYSTEM SIZING WORKSHEET. Page 13 and 14 you will find a sample of EarthLinked System Performance Tables.

Performance Tables (Training Sample Only)

AIR COOLING – Prime Series 65°F Earth Temperature

Nominal Capacity (kBTUH)	Cooling Output	H1B		V2/D2 V1.5/D1.5		V1/D1	
		BTUH	EER	BTUH	EER	BTUH	EER
25	Maximum Capacity	35500	21.6	32500	19.7	34600	21.0
	Design Total Capacity	29900	15.5	27400	14.1	29200	15.0
	Design Sensible Capacity	23300	--	21400	--	22700	--
30	Maximum Capacity	43600	22.2	40000	20.3	42500	21.5
	Design Total Capacity	37600	15.9	34500	14.5	36700	15.4
	Design Sensible Capacity	29300	--	26800	--	28600	--
36	Maximum Capacity	49800	22.2	45600	20.3	48600	21.5
	Design Total Capacity	43000	15.9	39400	14.5	42000	15.4
	Design Sensible Capacity	33500	--	30700	--	32700	--
40	Maximum Capacity	52900	21.6	48500	19.7	51600	21.0
	Design Total Capacity	45700	15.5	41900	14.1	44600	15.0
	Design Sensible Capacity	34300	--	31500	--	33500	--
50	Maximum Capacity	63300	21.8	58000	19.9	61800	21.2
	Design Total Capacity	54700	15.7	50100	14.3	53400	15.2
	Design Sensible Capacity	41000	--	37500	--	40000	--
60	Maximum Capacity	75900	21.6	69500	19.7	74000	21.0
	Design Total Capacity	65500	15.5	60000	14.1	63900	15.0
	Design Sensible Capacity	47200	--	43300	--	46000	--

Size the system using LIT-150. Actual system capacity and efficiency will vary depending on how it is operated and maintained, input power to other system components, and local soil thermal conductivity

HCM REQUIRED

Note: Hybrid Cooling Module (HCM) should be used in any **cooling dominant application** where soil thermal conductivity is unknown or known to be less than 1 BTU/hr.ft.°F

Performance Tables

(Training Sample Only)

AIR HEATING – Prime Series 65°F Earth Temperature

Nominal Capacity (kBTUH)	Heating Output	H1B		V2/D2 V1.5/D1.5		V1/D1	
		BTUH	COP	BTUH	COP	BTUH	COP
25	<i>Maximum Capacity</i>	40200	5.0	37400	4.7	36200	4.5
	<i>Design Capacity</i>	25400	3.9	23500	3.6	22800	3.5
30	<i>Maximum Capacity</i>	47900	5.0	44500	4.7	43100	4.5
	<i>Design Capacity</i>	30300	3.9	28200	3.6	27300	3.5
36	<i>Maximum Capacity</i>	56400	5.2	52500	4.8	50800	4.7
	<i>Design Capacity</i>	37600	4.0	34900	3.7	33800	3.6
40	<i>Maximum Capacity</i>	62600	5.0	58200	4.7	56300	4.5
	<i>Design Capacity</i>	41700	3.9	38800	3.6	37600	3.5
50	<i>Maximum Capacity</i>	78900	5.0	73400	4.7	71000	4.5
	<i>Design Capacity</i>	53600	3.9	49800	3.6	48300	3.5
60	<i>Maximum Capacity</i>	94200	5.0	87600	4.7	84800	4.5
	<i>Design Capacity</i>	58900	3.9	54800	3.6	53000	3.5

Size the system using LIT-150. Actual system capacity and efficiency will vary depending on how it is operated and maintained, input power to other system components, and local soil thermal conductivity

EarthLinked®

SYSTEM SIZING GUIDE

AIR COOLING, 105%



EARTHLINKED
TECHNOLOGIES

DOMINANT LOAD: **COOLING**

SIZING TO: **105% OF COOLING LOADS**

1/3

➔ This worksheet applies to systems using a DX air handler or cased coil.

1) Heating and Cooling Loads:

Determine heating and cooling requirements (heat gain and heat loss) of the structure, based on the ACCA Manual J (latest edition) procedure using the **ASHRAE 99.6% heating design temperature** and the **0.4% cooling design temperature** from the [EarthLinked® System Sizing and Performance Tables \(SSPT - section III\)](#). Elite RHVAC or Wrightsoft Right-J software is recommended.

2) Domestic water heating

If domestic water heating by Heat Recovery Module (HRM) is part of the system, **for each occupant add 1,000 BTUH to the Heating Load.**

Summer Design Temp: **93.8 °F**

Total Cooling Load: **41,812 BTUH**

Sensible Cooling Load: **37,358 BTUH**

Winter Design Temp: **20.7 °F**

Heating Load: **37,290 BTUH**

3) Local Earth Temperature

Determine local earth temperature from Temperature Map.

Site Location: **Atlanta**

GA

Earth Temp: **65 °F**

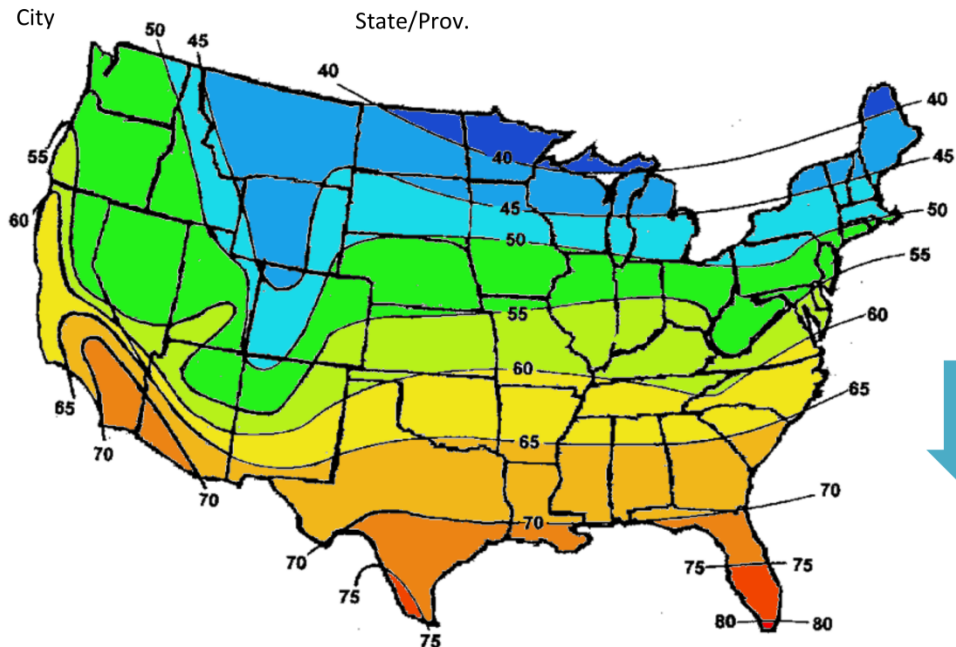

EARTH TEMPERATURES IN CONTIGUOUS UNITED STATES AND SOUTHERN CANADA

4) System parameters:

Locate the System Performance Data in the [Air Cooling Performance Table](#) (SSPT-section IV) based on:

- Compressor type: **Prime** (Classic Series or Prime Series)
- Earth Temperature **65** (see step 3)
- Earth Loop Configuration **V1** (H1, V1, D1, V1.5, D1.5, V2 or D2 based upon available land area and geology of the earth at the site)

5) System Size and Cooling Output:

- Size of the system determined by: **Total Cooling Output** and **Sensible Cooling Output**

Use the appropriate [Air Cooling Performance Table](#) (SSPT-section IV) selected based on step 4 above.

- The initial selection of a system size (nominal capacity) should have a **Total and Sensible Cooling outputs of at least 105% of the Total and Sensible Cooling Loads respectively.**

System Size (nominal capacity)	Cooling Output (Design Capacities)	Cooling Loads (see Step 2)
50 kBTUH	TOTAL: 53,400 BTUH SENSIBLE: 40,000 BTUH	TOTAL: 41,812 BTUH SENSIBLE: 37,358 BTUH

Is Total Cooling Output 5% greater than Total Cooling Load? YES NO

Is Sensible Cooling Output 5% greater than Sensible Cooling Load? YES NO

Does the performance table require that the unit be equipped with an **HCM**? YES NO
(**HCM**: Hybrid Cooling Module is a required component to enhance cooling mode system efficiency and performance when required by the performance tables or for applications having **low thermal conductivity soils** or **sustained high summer temperatures** above cooling design temperature)

6) Heating Output:

From the appropriate [Air Heating Performance Table](#) (SSPT-section IV) determine the Heating Output using:

- System parameters (see Step 4)
- System size (see Step 5)

Supplemental heat with a rating of at least 20% of the heating load, in BTUH, is a required component of the system.

Re-Enter the system size (see Step 5) and the Heating Load value (see Step 2) below:

System Size (nominal capacity)	Heating Output (Design Capacity @ 100% Load)	Heating Load (see Step 2)
50 kBTUH	48,300 BTUH	37,290 BTUH

Is Heating Output at least 100% of the heating load? YES NO

Does the performance table require that the unit be equipped with an **HPE**? YES NO

(**HPE**: Heating Performance Enhancement Kit is a required component to enhance heating performance for Horizontal loops where ground temperature is 70°F or higher. It is **recommended for any applications where automatic change-over or switching between heating and cooling occurs within a 24-hour period**)

Ordering and Warranty process

You will need a login to access EarthLinked's Dealer website (<https://earthlinked.com/dealers/>). Following training you will receive an email with a temporary 30-day Dealer login until you sign on and become an EarthLinked Dealer.

ORDERING

EarthLinked has an online ordering tool, accessible at <https://earthlinked.com/dealers/new-order/>.

Once your order is placed, you will be automatically notified by email when its status changes: "Order Accepted", "Order in Progress" and "Order Shipped".

You will be able to view all your past orders here: <https://earthlinked.com/dealers/orders/>.

WARRANTY

EarthLinked has an online warranty registration tool, accessible at <https://earthlinked.com/warranty/>.

EarthLinked Geothermal Systems should be registered within 60 days of installation / unit start-up. ETI may not credit the dealer's account for claimed allowances if the appropriate warranty registration is not on file at ETI within 60 days of installation / unit start-up. Should EarthLinked not receive the product registration in time, the warranty start date would be the unit ship date.

To get more information on warranty registration, warranty coverage and warranty claims, go here: <https://earthlinked.com/dealers/warranty-info/>.

Key Corporate Contacts

Technical Support

- **Jim McDuffie** | jmcduffie@Earthlinked.com | (863) 701-0096 #233
Technical assistance on existing systems
Warranty claims
- **John Webster** | jwebster@Earthlinked.com | (863) 701-0096 #235
Training and field service
Design and Technical assistance on new systems

Customer Service

- **Gail Barna** | gbarna@Earthlinked.com | (863) 701-0096 #224
Pricing & order processing
Shipping estimates, timing, logistics
- **Debbie Snider** | dsnider@Earthlinked.com | (863) 701-0096 #233
Pricing & order processing
Shipping estimates, timing, logistics

Sales

- **Phil Albertson** | palbertson@Earthlinked.com | (317) 385-1064 #235
New Dealer sales
Product information & dealer pricing
- **Your Area Manager**

General contact

- **Telephone:** (863) 701-0096
- **Toll-free:** (866) 211-6102

Earth Loop Review Questions

1. All earth loop bore holes must be the same _____
2. All diagonal earth loop bore holes must be the same _____
3. Vertical earth loops must be separated by at least _____ feet
4. When brazing all joints, always use _____% silver brazing alloy
5. Before brazing, ALWAYS displace the _____ inside the earth loop tubing with _____
6. Finished manifolds must be encapsulated with _____ in order to ensure that the manifolds remain _____
7. Horizontal earth loops must be _____ within _____ overall
8. A new homeowner knew where the manifolds were located because the installer provided _____
9. The buried line set leading from the compressor to the earth loop manifolds must be separated by a minimum of _____
10. The maximum equivalent line set length between the manifolds and air handler or cased coil is _____

Space Heating & Cooling Review Questions

1. What calculation must always be performed for proper equipment sizing?

2. The condition where the heat being lost from the building is equal to the heat being provided by the heat pump is called the _____

3. EarthLinked space heating equipment must utilize _____

4. Maximum linear distance between the air handler and earth loops is _____ feet
5. When specifying an air handler, it must be determined whether the application is _____ or _____
6. Air flow design is _____ CFM/nominal kBTU
7. Maximum test pressure on the compressor section is _____ psi
8. Minimum vacuum level draw during evacuation is _____ microns
9. Refrigerant should never rise above the _____ sight glass of the ACC



Dealer-trainee Information Form

Please print clearly.

Name:	
Company Name:	
Company Mailing Address:	
City / State / Zip	/ /
Telephone / Fax:	/
Email Address:	

(Signature)

(Date)



EarthLinked Dealer-trainee Exam

Name: _____ Date: _____

EARTH LOOPS

1. All earth loop bore holes must be the same _____ (**diameter; depth; angle; consistency**)
2. All diagonal earth loop bore holes must be the same _____ (**diameter; depth; angle; consistency**)
3. Keep the inside of the earth loop tubing clean while brazing by ALWAYS displacing the air with _____ (**water; soap; nitrogen; a vacuum**)
4. In order to insure that the manifolds remain vertical, finished manifolds must be encapsulated with _____ (**grout; concrete; sand; gravel**)
5. Horizontal earth loops must be level within _____ overall (**6"; 12"; 18"; 24"**)
6. The buried line set leading from the compressor to the earth loop manifolds must be separated by a minimum of _____ (**12"; 18"; 5'; 7'**)
7. The maximum equivalent line set length between the manifolds and air handler or cased coil is _____ (**75'; 100'; 125'; 150'**)
8. A new homeowner knew where the manifolds were located because the installer provided _____ (**GPS coordinates; a marker stone; triangulated coordinates**)
9. Separate vertical earth loops by at least _____ (**1'; 2'; 4'; 7'**)
10. Always use 15% silver brazing alloy when brazing _____ joints (**all; underground; none**)



SPACE HEATING & COOLING

11. Supplemental heat is required of all Earthlinked heating equipment True False
12. Manual J load calculations must be utilized with all Earthlinked space heating and cooling equipment True False
13. The maximum linear distance between the air handler and earth loops is _____
(75'; 100'; 125'; 150')
14. Maximum test pressure on the compressor section is 150 psi True False
15. A minimum of 400 microns of vacuum level must be drawn during evacuation True
 False
16. Refrigerant should never rise above the _____ sight glass of the ACC (**top; middle; bottom**)
17. The condition where the heat escaping a building is equal to the heat supplied by the heat pump is the _____ (**design temperature; balance point; bin temperature; mean earth temperature**)
18. All Earthlinked refrigerant-to-air systems require 400 CFM/ton for proper operation
 True False
19. It must always be determined whether the application is _____ or _____ when specifying an air handler or cased coil (**smaller; larger; vertical; horizontal**)
20. All compressor units can be installed indoors or outdoors True False



Training Assessment Form

Presenter: _____ Date: _____

Please rate the following on a scale of 1 – 10, where 1 = “**strong no**” and 10 = “**strong yes.**”

1. Were your desired objectives met? _____
2. Was the meeting content relevant? _____
3. Was your interest maintained during the meeting? _____
4. Did you have sufficient opportunity for interaction? _____
5. Was the content logically ordered and presented? _____
6. Was the presenter responsive to your questions? _____
7. Was the presenter knowledgeable about the topic? _____
8. Would you like to hear the presenter again? _____
9. Will the information shared here increase your effectiveness on the job? _____

10. What information was MOST helpful?

11. What information was LEAST helpful?

12. Were the refreshments and/or meeting accommodations acceptable? _____

13. Were the collateral materials helpful? _____

14. Suggestions for improving our meetings in the future:



EARTHLINKED
TECHNOLOGIES

EarthLinked Technologies, Inc.

4151 S. Pipkin Road

Lakeland, Florida 33811 USA

Phone: 863-701-0096

Toll-free: 866-211-6102

earthlinked.com

ETI-LIT-259