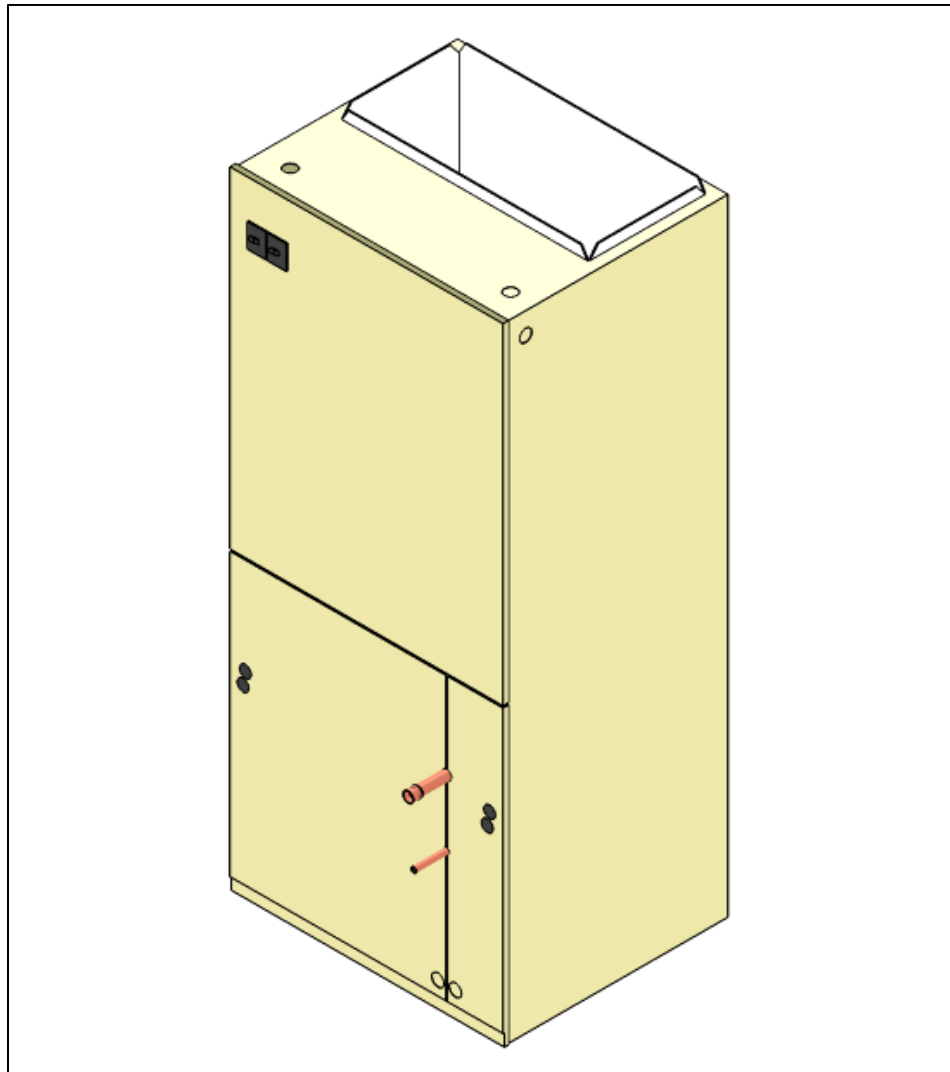




**EARTHLINKED**  
**TECHNOLOGIES**

**AVS Series Air Handlers**  
***Installation Manual***  
**for**  
**CLASSIC SERIES SYSTEMS**  
**Models SC, SD, and SDH**



## Table of Contents

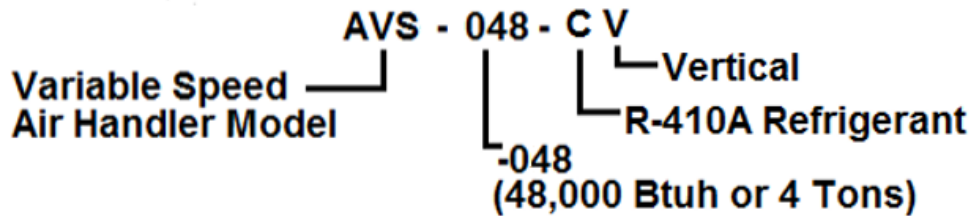
Model Nomenclature .....	4
Safety.....	5
Equipment Manuals .....	5
Installation.....	6
Component Matching .....	6
Air Handler Placement .....	7
Refrigeration .....	9
Line Set.....	9
TXV Kit Installation .....	11
Electrical Data.....	21
Thermostat Connections .....	21
Wiring Diagram.....	21
Speed Taps & Air Flow.....	21
Appendix A – Supplemental Installation Instructions .....	25
Appendix B – AVS Series (AEM) Parts List.....	31

## List of Figures

Figure 1. Classic Series Component Matchup .....	6
Figure 2. General Layout of System Components.....	7
Figure 3. General Air Handler Physical Dimensions (Part 1) .....	8
Figure 4. General Air Handler Physical Dimensions (Part 2) .....	9
Figure 5. Line Set Sizes .....	9
Figure 6. Air Handler Line Set Separation.....	10
Figure 7. TXV Control .....	11
Figure 8a. TXV Control Installed on Vertical (upflow/downflow) Air Handler.....	12
Figure 8b. TXV Control installed next to Vertical (upflow/downflow) Air Handler .....	13
Figure 8c. TXV Control Installed next to Horizontal Left Flow Air Handler .....	14
Figure 8d. TXV Control Installed next to Horizontal Right Flow Air Handler.....	14
Figure 8e. TXV Control Box Dimensions .....	15
Figure 8f. TXV Control Box mounting Positions .....	16
Figure 9. Positioning the Pressure Equalizer Tee.....	17
Figure 10. Thermal Bulb Positioning .....	18
Figure 11. Clamping the Thermal Bulb.....	19
Figure 12. Insulating the Thermal Bulb.....	19
Figure 13. TXV Liquid Line Connections .....	20
Figure 14. AVS Electrical Data.....	22
Figure 15. AVS Thermostat Connections (SC(A) Compressor Unit).....	22
Figure 16. AVS Wiring Diagram .....	23
Figure 17. AVS Speed Taps and Air Flow Data .....	24

## Model Nomenclature

### Heat/Cool and Cool Only Air Handlers



### **Disclaimer**

Proper installation and service of EarthLinked® Heating and Cooling System Components is essential to reliable performance. All EarthLinked® components must be installed and serviced by a technician authorized by Earthlinked Technologies. Installation and service must be in accordance with the instructions set forth in this manual. Failure to provide installation and service by an authorized installer consistent with this manual will void the limited warranty coverage for the system.

Earthlinked Technologies shall not be liable for any defect, unsatisfactory performance, damage or loss, whether direct or consequential, relative to the design, manufacture, construction, application or installation of the field specified components.

Earthlinked Technologies, Inc.  
4151 South Pipkin Road  
Lakeland, Florida 33811  
tel. 863-701-0096 • fax 863-701-7796  
info@earthlinked.com • [www.earthlinked.com](http://www.earthlinked.com)  
CSI # 23 80 00

## Safety

**Warning, Caution** and **Important** notices appear throughout the manual. Read these items carefully before attempting installation, servicing or troubleshooting the equipment.



### IMPORTANT!

Notification of installation, operation or maintenance information which is important, but which is not hazardous.



### CAUTION!

Indicates a potentially hazardous situation or an unsafe practice, which if not avoided, may result in injury, or equipment or property damage.



### WARNING!

Indicates a hazardous situation, which if not avoided will result in serious injury or death, or equipment or property damage.

## Equipment Manuals

The following is a listing of the equipment installation manuals that are provided with each component specified for this EarthLinked<sup>®</sup> system.



### IMPORTANT!

Read and follow all installation instructions in these manuals, appropriate for the EarthLinked<sup>®</sup> system being installed, **BEFORE** initiating the Start-Up procedure.

*Classic Series SC, SD, or SDH Quick-Start Instructions (as appropriate)*

*TXV Kit Installation Manual*

# Installation

## Component Matching


AVS Model variable speed air handlers are ready for vertical installation as shipped. They are manufactured for vertical and horizontal applications, and are field convertible for horizontal left or right applications in the field, as shipped. Supplemental electric strip heat providing a minimum 20% of the nominal heating output of the system is required. Electric heat kits listed in Figure 1 are available in a range of capacities for field installation and are purchased separately.

These air handlers are equipped with a distributor designed for providing optimum performance in the cooling mode and the heating mode. In addition, this air handler includes a TXV Kit that is field installed external to the air handler that is required to make the system operational in the cooling mode when matched with the appropriate model EarthLinked® Classic Series compressor unit as shown in Figure 1.

CLASSIC SERIES COMPRESSOR UNIT MODEL/CAPCITY	AIR HANDLER* MODEL	HEATER** KW	TXV-KIT MODEL ***
-024 (2.0 Tons)	AVS – 030 – CV	5, 8* or 10	TXV – 2430CE
-030 (2.5 Tons)	AVS – 036 – CV	5, 8* or 10	TXV – 2430CE
-036 (3.0 Tons)	AVS – 048 – CV	5, 10 or 15	TXV – 3672CE
-042 (3.5 Tons)	AVS – 048 – CV	5, 10 or 15	TXV – 3672CE
-048 (4.0 Tons)	AVS – 060 – CV	5, 10, 15 or 20	TXV – 3672CE
-054 (4.5 Tons)	AVS – 060 – CV	5, 10, 15 or 20	TXV – 3672CE
-060 (5.0 Tons)	AVS – 060 – CV	5, 10, 15 or 20	TXV – 3672CE
*Air handlers shipped for vertical application. Field convertible to horizontal. **8kW heater is not stocked. Special order electric heater. ***TXV Kit is included with air handler for field installation			

**Figure 1. Classic Series Component Matchup**

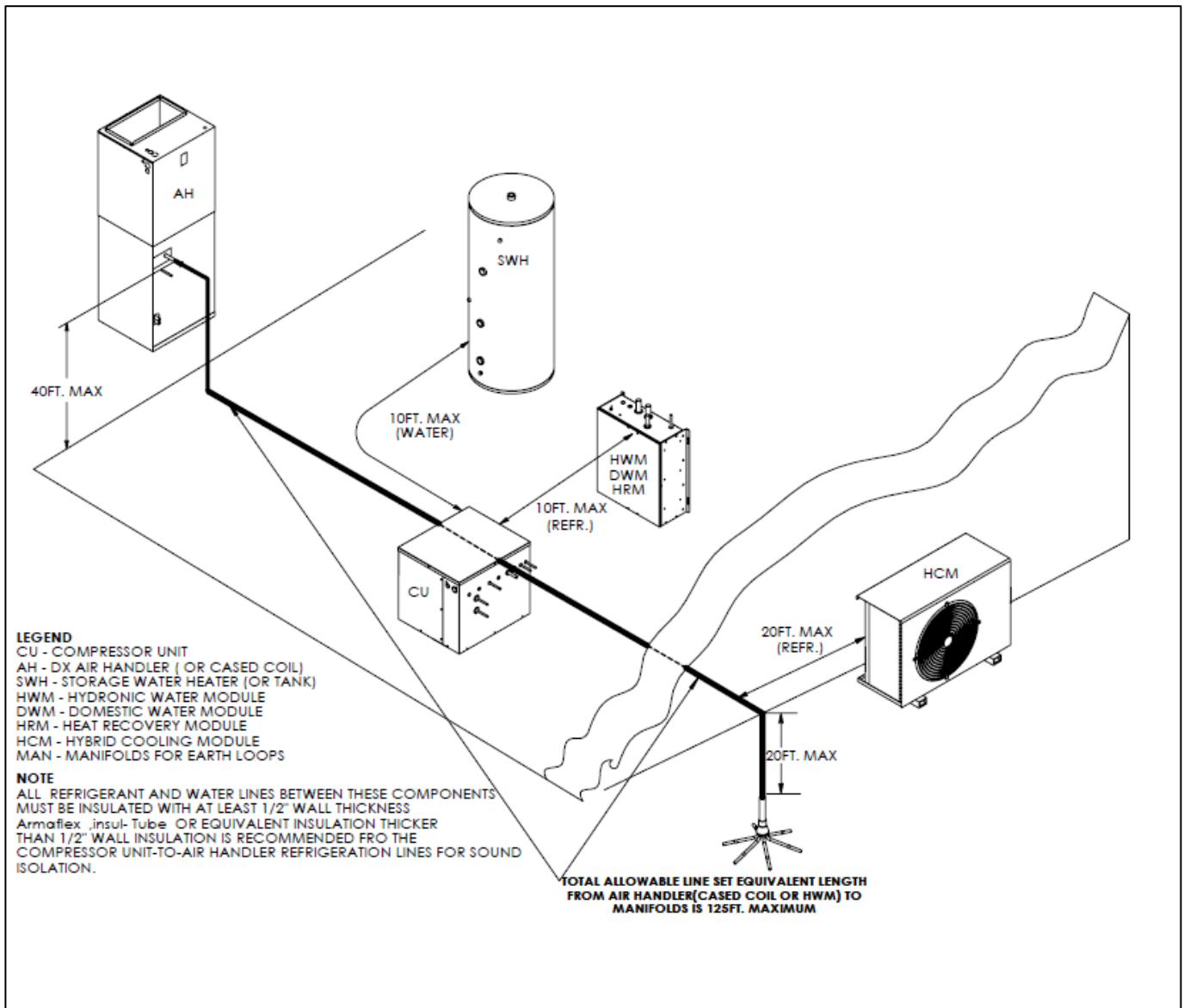
## Air Handler Placement



**WARNING!**

**WEAR ADEQUATE PROTECTIVE CLOTHING AND PRACTICE ALL APPLICABLE SAFETY PRECAUTIONS WHILE INSTALLING THIS EQUIPMENT. FAILURE TO DO SO MAY RESULT IN EQUIPMENT AND/OR PROPERTY DAMAGE, PERSONAL INJURY OR DEATH.**

Guidelines for the air handler placement relative to the compressor unit and other EarthLinked® system components are shown in Figure 2.



**Figure 2. General Layout of System Components**

Dimensions for the air handlers are illustrated and listed in Figures 3 and 4.

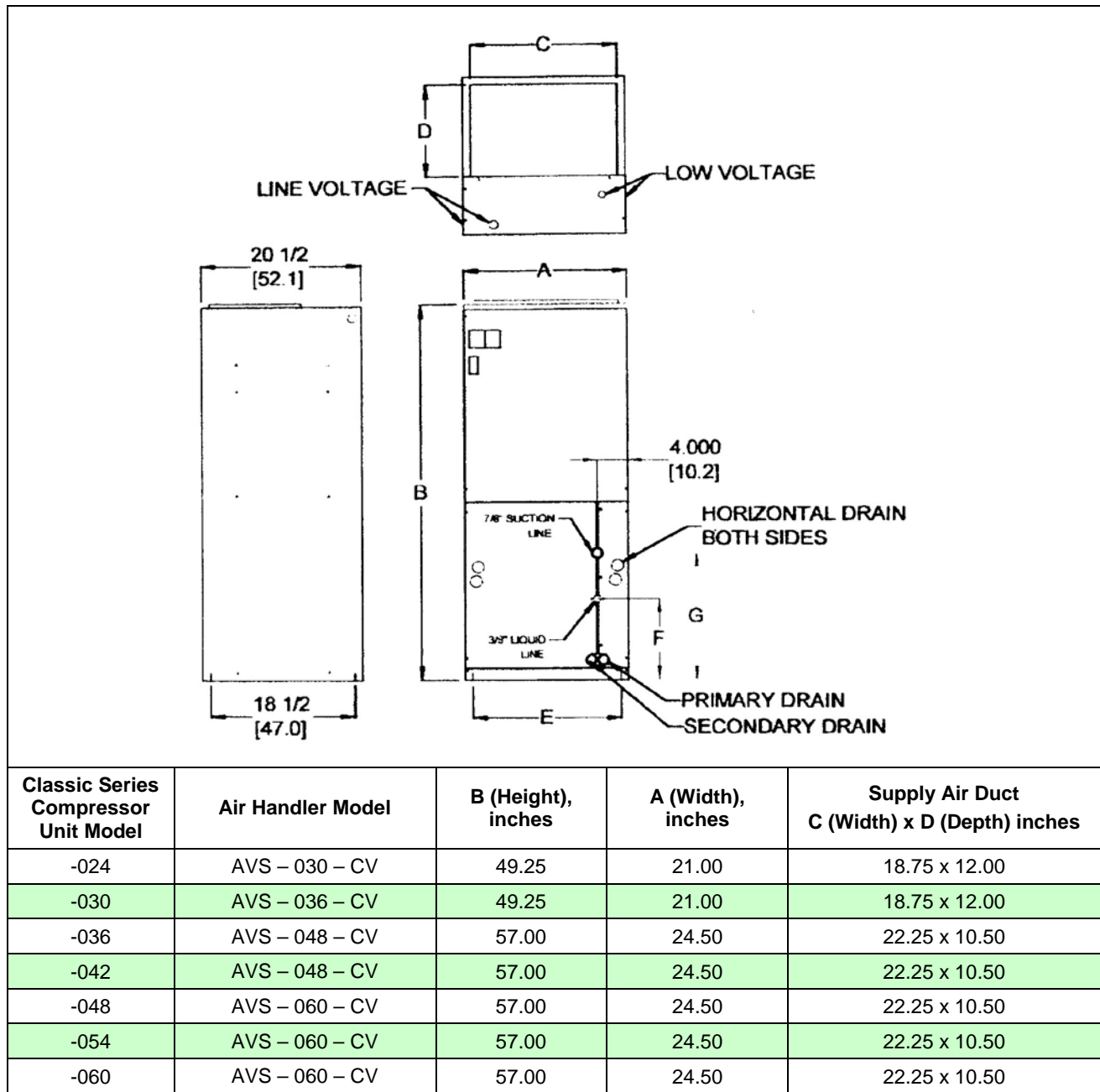


Figure 3. General Air Handler Physical Dimensions (Part 1)



Classic Series Compressor Unit Model	Air Handler Model	Refrigerant Suction OD, inches	Refrigerant Liquid OD, inches	Filter Size, inches	Return Air Duct E (width) inches
-024	AVS – 030 – CV	7/8	3/8	16 x 20	18.50
-030	AVS – 036 – CV	7/8	3/8	16 x 20	18.50
-036	AVS – 048 – CV	7/8	3/8	20 x 20	22.00
-042	AVS – 048 – CV	7/8	3/8	20 x 20	22.00
-048	AVS – 060 – CV	7/8	3/8	20 x 20	22.00
-054	AVS – 060 – CV	7/8	3/8	20 x 20	22.00
-060	AVS – 060 – CV	7/8	3/8	20 x 20	22.00

**Figure 4. General Air Handler Physical Dimensions (Part 2)**

## Refrigeration

### Line Set

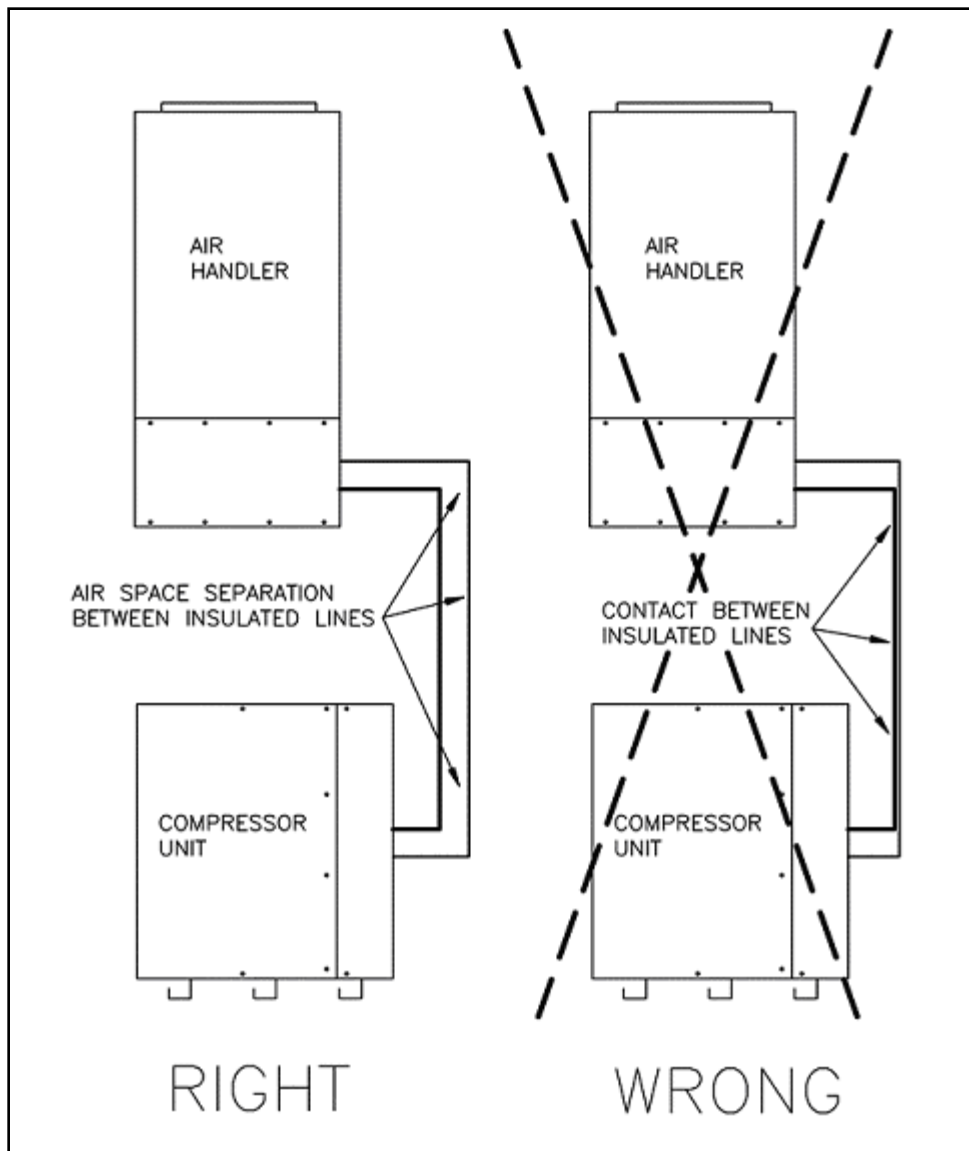
Line set sizes for Air Handlers connecting to the matching compressor units are listed in Figure 5. Line set liquid and vapor lines are to be insulated with Armaflex®, Insul-Lock® or equivalent tubing insulation at least ½” wall thickness. For interior living areas, thicker walled insulation will reduce sound level.

<b>LINE SET ADAPTERS REQUIRED FOR THE AIR HANDLER, CASED COIL, HYDRONIC WATER MODULE AND DOMESTIC WATER MODULE ARE FIELD SUPPLIED. CHECK ALL APPROPRIATE COMPRESSOR UNIT STUB-OUT TUBING SIZES FOR REQUIRED FIELD SUPPLIED ADAPTERS!</b>					
EARTHLOOP, AIR HANDLER, CASED COIL LINE SETS			HWM LINE SETS		
COMPRESSOR UNIT SIZE	LINE SET O.D., INCHES		HWM MODEL	LINE SET O.D., INCHES	
	LIQUID*	VAPOR*		LIQUID*	VAPOR*
2.0 Tons (-024)	3/8	5/8	-024C/-1836	3/8	1/2
2.5 Tons (-030)	3/8	3/4	-030C/-1836	3/8	1/2
3.0 Tons (-036)	1/2	3/4	-036C/-1836	3/8	1/2
3.5 Tons (-042)	1/2	3/4	-042C/-4248	1/2	5/8
4.0 Tons (-048)	1/2	7/8	-048C/-4248	1/2	5/8
4.5 Tons (-054)	1/2	7/8	-054C/-5472	1/2	3/4
5.0 Tons (-060)	1/2	7/8	-060C/-5472	1/2	3/4

\*Liquid and Vapor lines must BOTH be insulated with Armaflex® or equivalent with at least 1/2” wall thickness for the full length of the line set.

**Figure 5. Line Set Sizes**

Both liquid and vapor lines running between the compressor unit and the air handler must be separated by an air space, as illustrated in Figure 6, to ensure system performance. The lines shall not be “bundled” by tying them together or by running both lines together, in contact with one another, within a single conduit, such as PVC pipe.



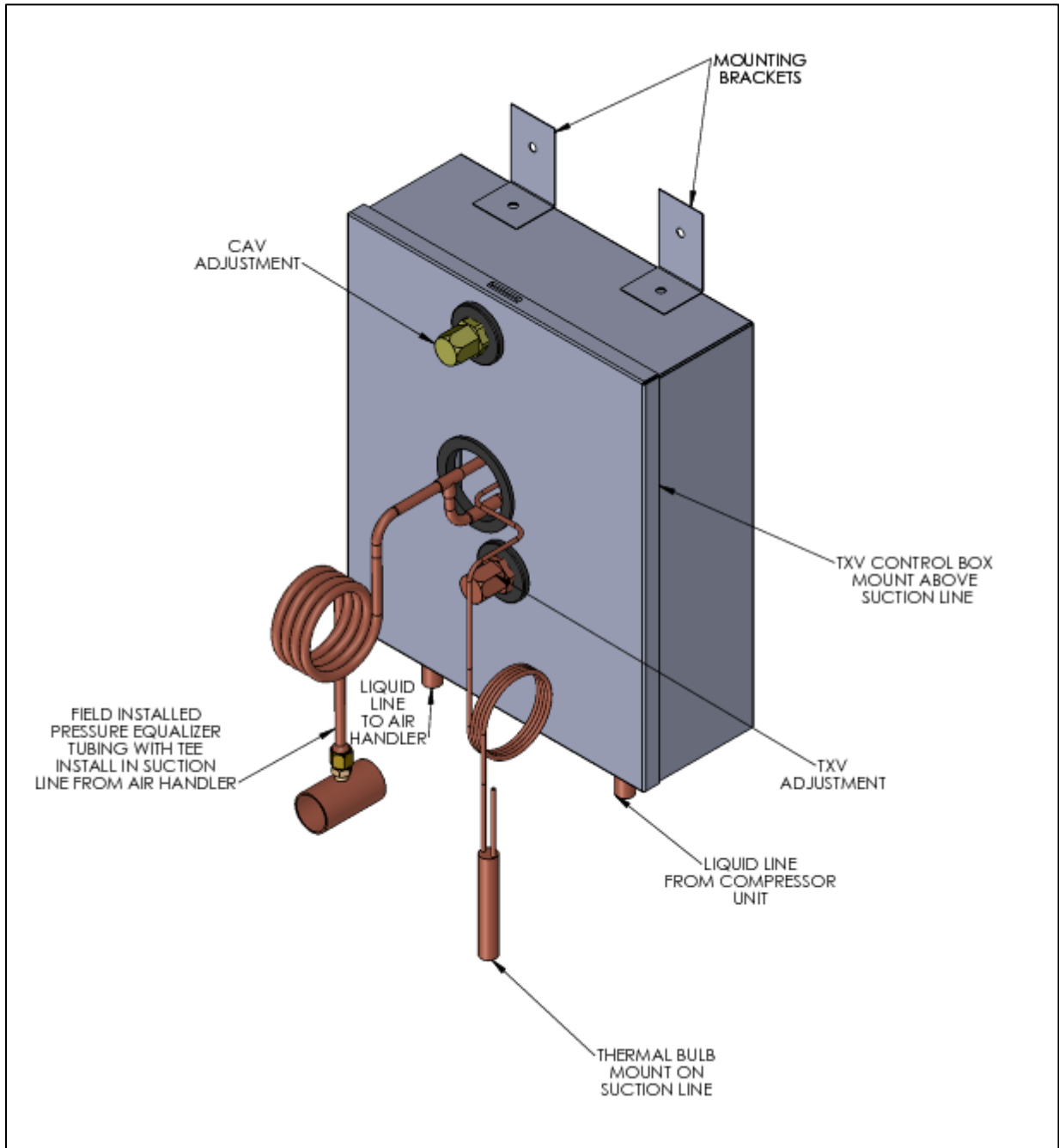
**Figure 6. Air Handler Line Set Separation**

## TXV Kit Installation

**Air Handlers are shipped with the matching TXV Kit that must be field installed to enable operation of the system in the cool mode.**

The following procedure is for the installation of the TXV Kit which must be done prior to making the line set connections to the air handler.

Figure 7 illustrates the TXV Kit as shipped with the external parts for field installation identified. In Figure 7, the pressure equalizer tubing and suction line Tee are shown connected to the control box for illustration purposes. These parts are shipped with the TXV control box and are field assembled to the control box and to the suction lines. The TXV (thermal expansion valve), CAV (cooling assist valve) and interconnecting tubing are located inside the control box to ensure performance.



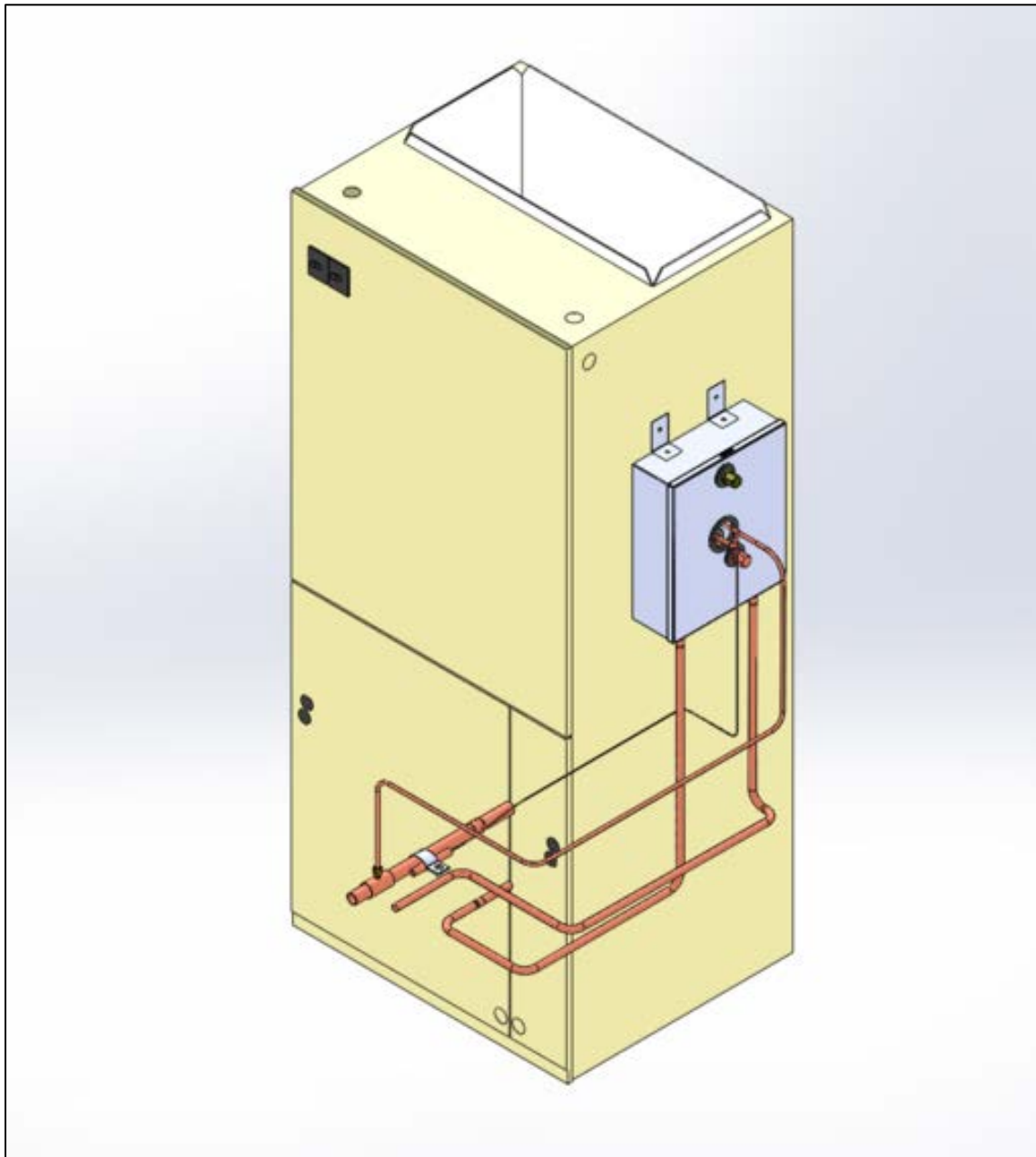
**Figure 7. TXV Control**

The TXV control box is field positioned external to the vertical (upflow or downflow) air handler and fastened to (1) the air handler as shown in Figure 8a, or (2) on a solid mounting surface immediately adjacent to the air handler as shown in Figure 8b. Locate the TXV control box to allow a service access of at least 12 inches in front of the box to adjust the TXV control.

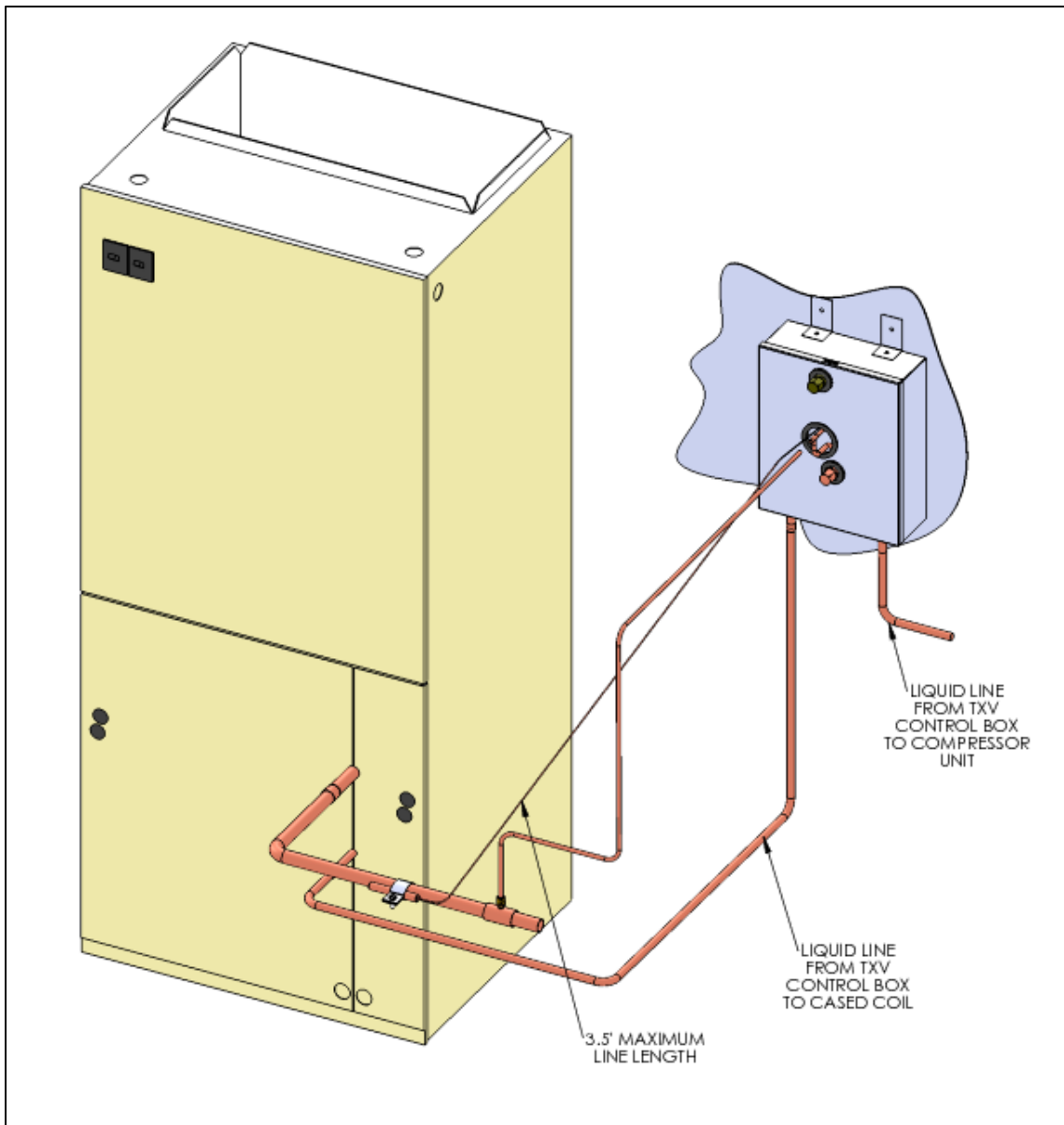


**Important!**

**The TXV control box must be located no more than 3-1/2 feet from the suction tube stub out on the air handler. The TXV control box must be mounted above the air handler tubing stub outs as shown.**



**Figure 8a. TXV Control Installed on Vertical (upflow/downflow) Air Handler**



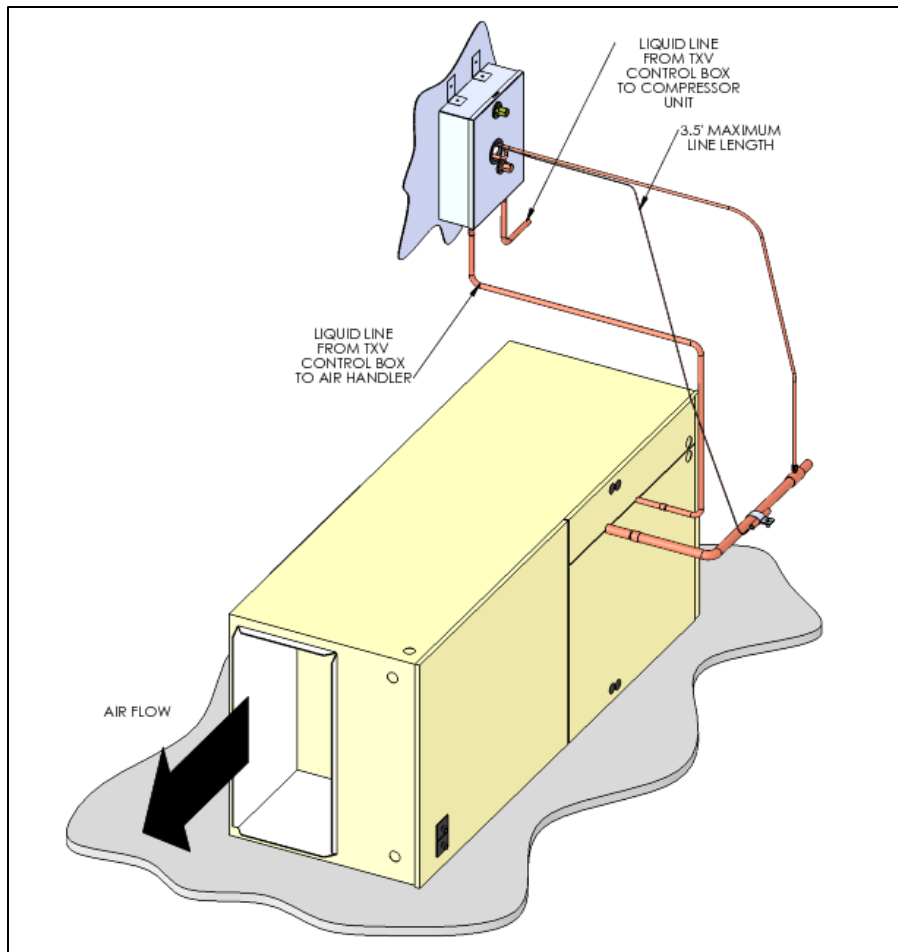
**Figure 8b. TXV Control installed next to Vertical (upflow/downflow) Air Handler**

For horizontal air handler applications (left or right air flow), the TXV control box is field positioned external to the air handler and can be fastened to (1) the cabinet side surface that is pointed upward, or (2) on a solid mounting surface immediately adjacent to the air handler as shown typically in Figures 8c and 8d.

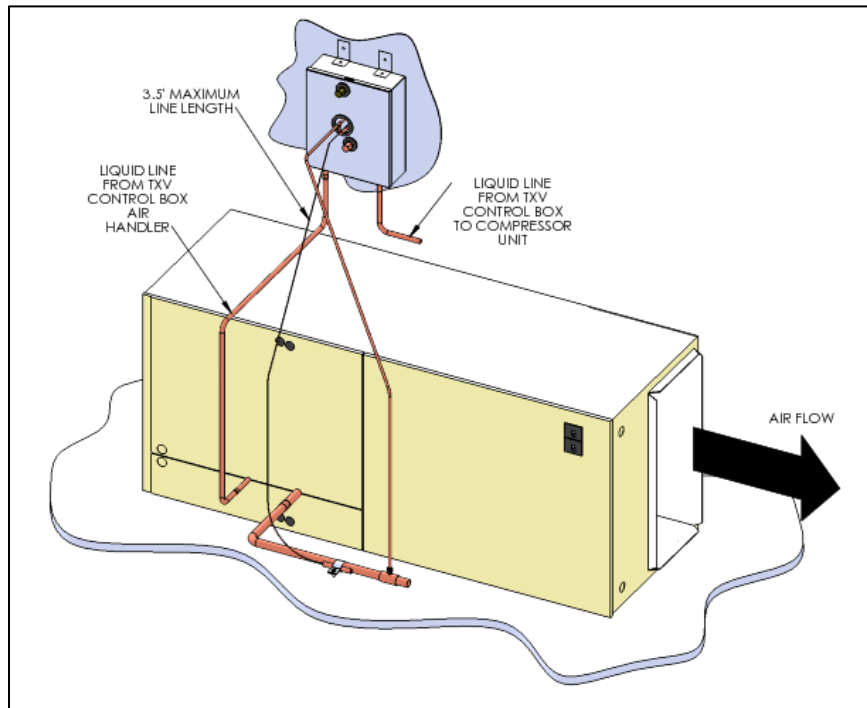


**Important!**

**The TXV control box must be located no more than 3-1/2 feet from the suction tube stub out on the air handler. The TXV control box must be mounted above the air handler tubing stub outs as shown.**

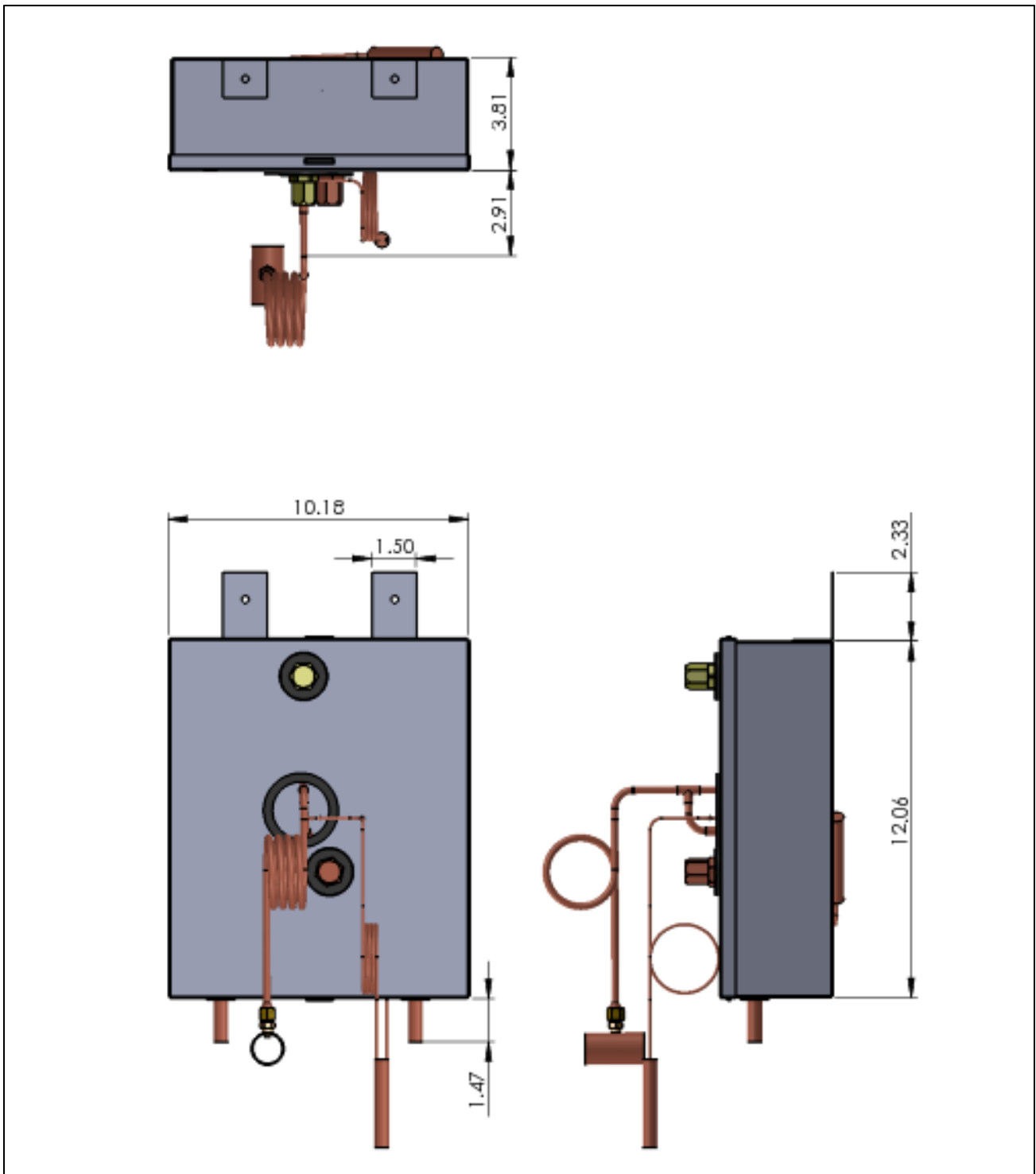


**Figure 8c. TXV Control Installed next to Horizontal Left Flow Air Handler**

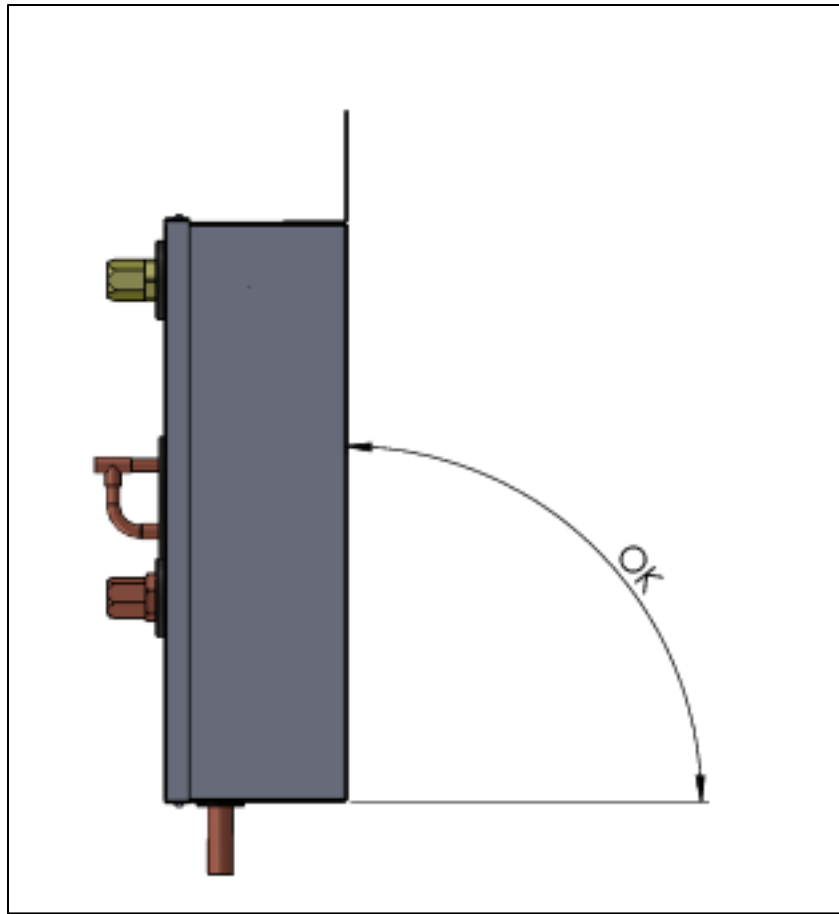


**Figure 8d. TXV Control Installed next to Horizontal Right Flow Air Handler**

For mounting purposes, the physical dimensions for the TXV Control Box are shown in figure 8e. The preferred mounting position for the TXV Control Box is vertical with the liquid line tube connections on the bottom. However, as shown in Figure 8f, the Control Box can be mounted from vertical to any angle up to 90 degrees (horizontal).



**Figure 8e. TXV Control Box Dimensions**



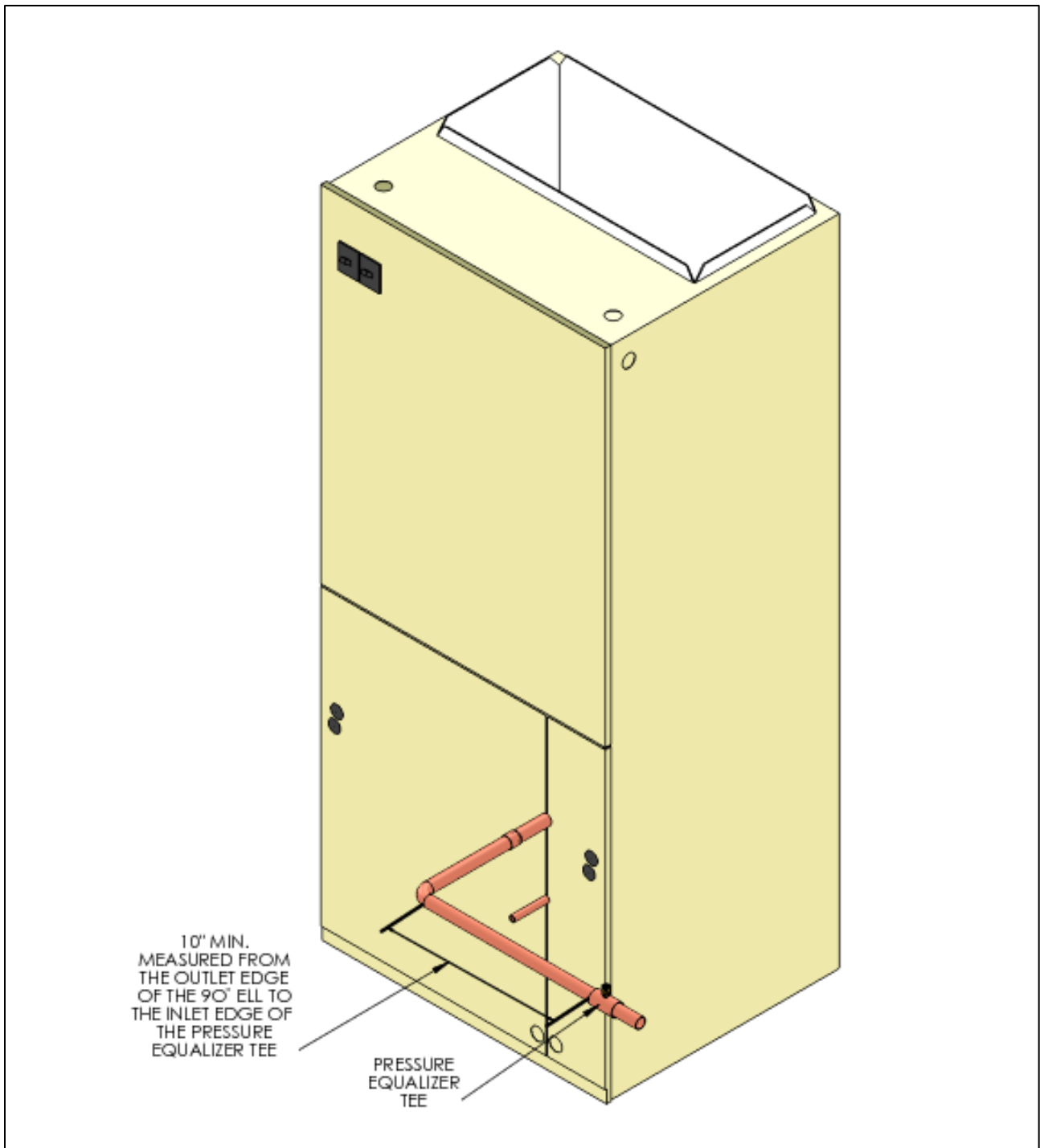
**Figure 8f. TXV Control Box mounting Positions**

The following steps and positioning requirements apply to installing the TXV Control to the air handler for vertical and horizontal applications. The vertical installation provides an illustrated example.

**Step 1:** Relieve the nitrogen holding charge on the air handler. Locate the TXV Control box within the 3-1/2 feet of the suction line stub out on the air handler. If the TXV control box is to be fastened to the air handler, be sure not to drill into the air handler internal components. **Fasten the TXV control box above the suction line stub out.**

**Step 2: Position the Pressure Equalizer Tee** on the suction tube at least 10 inches downstream from the 90°ell, as shown in Figure 9. Remove the core from Schrader valve on the Tee.

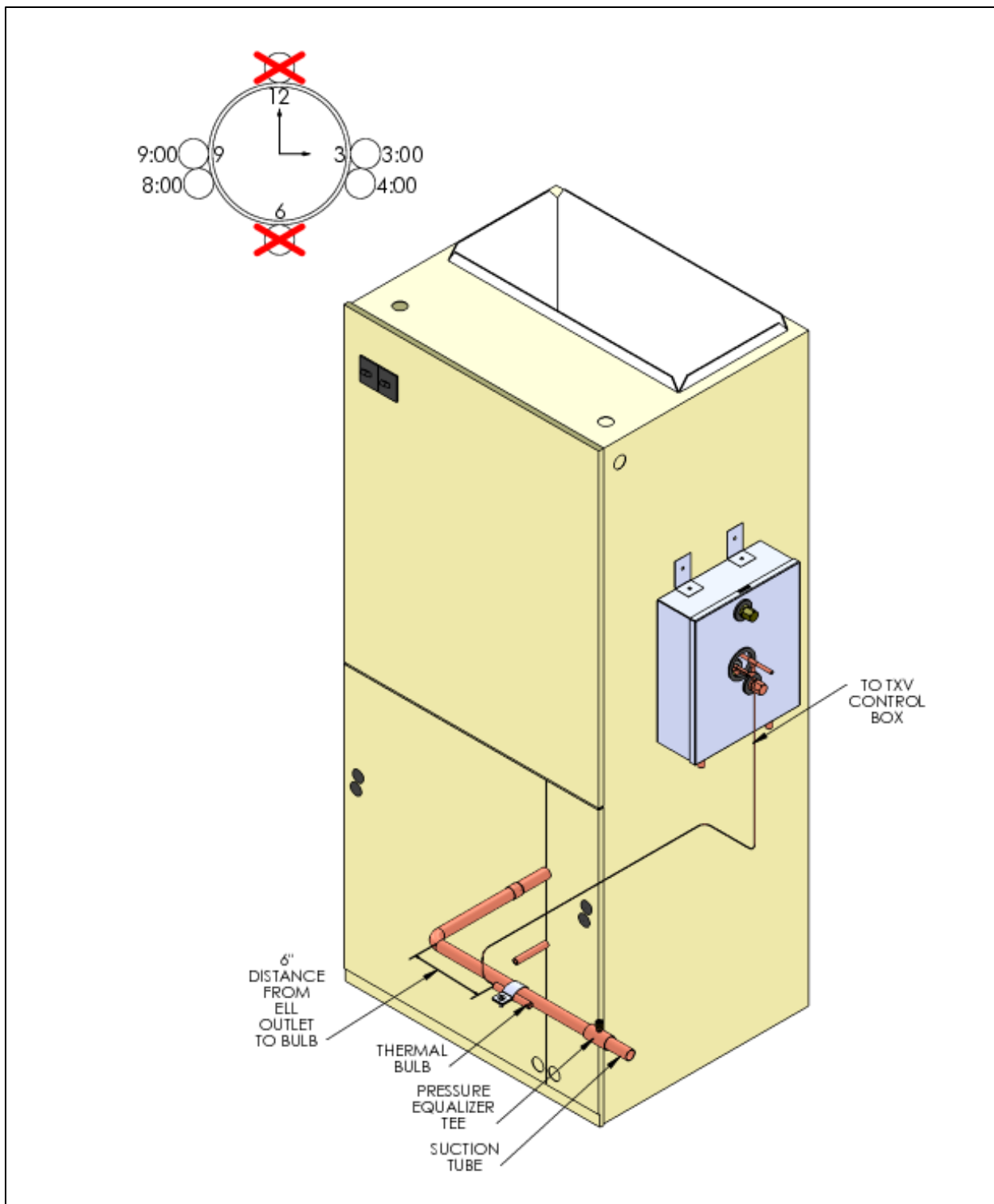




**Figure 9. Positioning the Pressure Equalizer Tee**

**Step 3:** The **Thermal Bulb** must be positioned and clamped to the suction tube 6 inches downstream from the 90° elbow as shown in the example illustrated in Figure 10. The **Thermal Bulb and suction tube must be horizontal** regardless of the air handler application (vertical or horizontal).

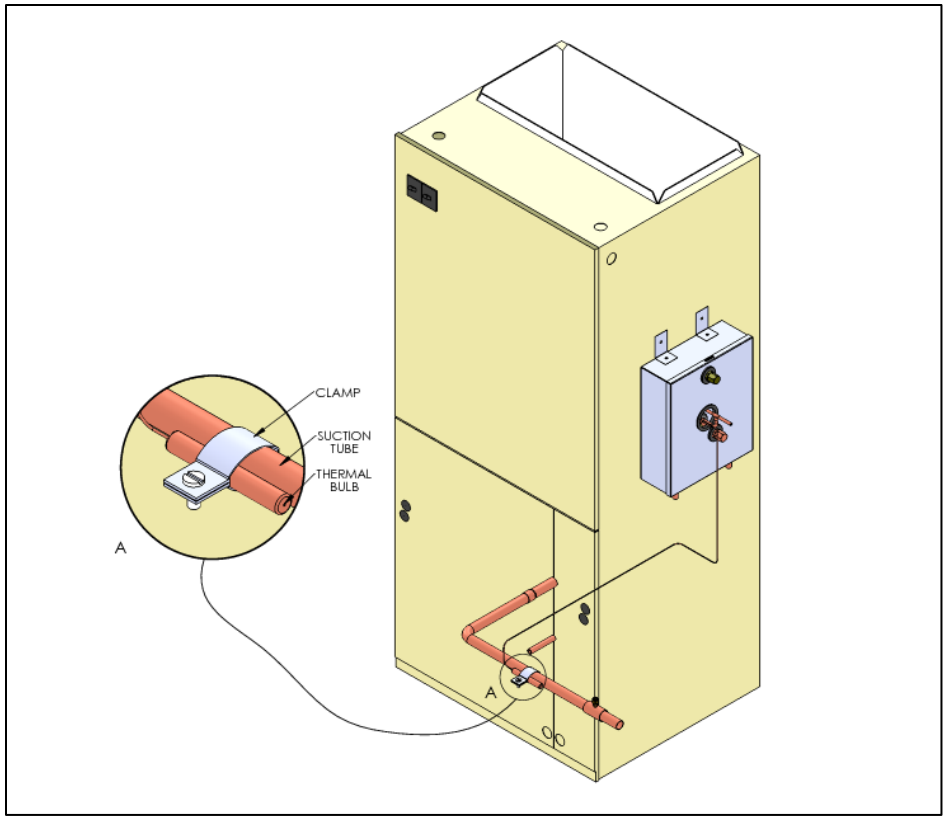
The Thermal Bulb must be positioned at the 3:00, 4:00, 8:00 or 9:00 positions on the suction tube as illustrated in Figure 10.



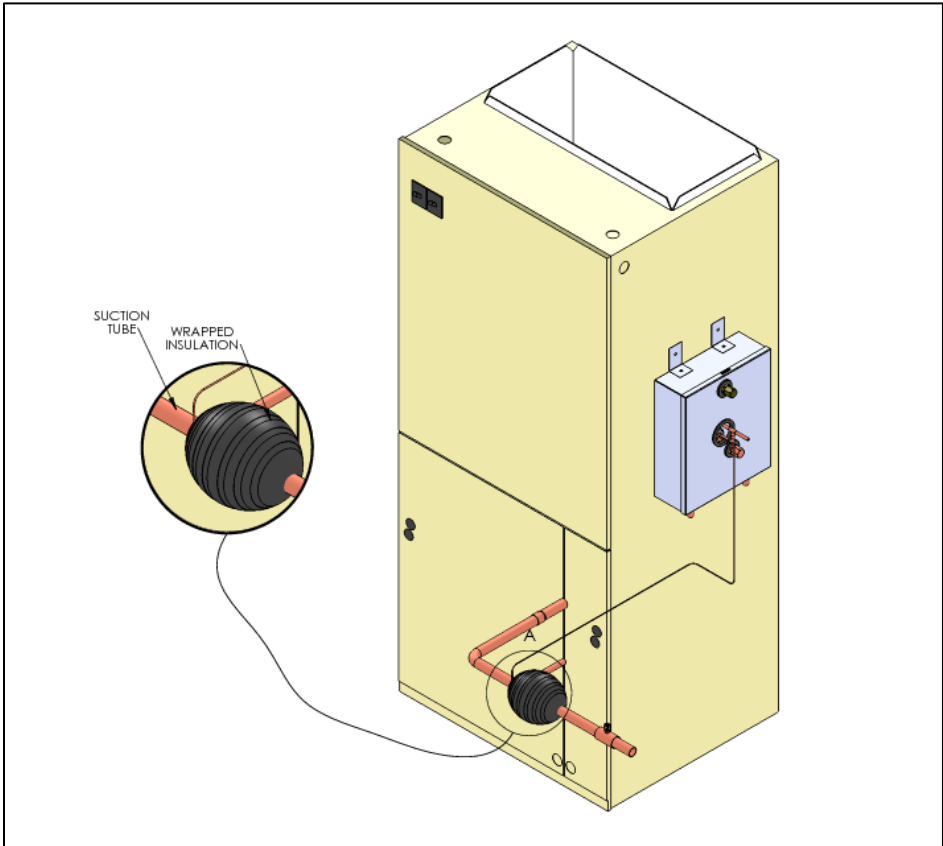
**Figure 10. Thermal Bulb Positioning**

**Step 4:** Clamp the thermal bulb firmly against the **clean suction tube** and parallel to it, as shown in Figure 11.

Isolate the Thermal Bulb from with a cold wet cloth while Nitrogen brazing the joints on the suction line. After the suction line has cooled, apply the supplied cork tape insulation around the Thermal Bulb to completely isolate it from the surrounding air, as shown in Figure 12.



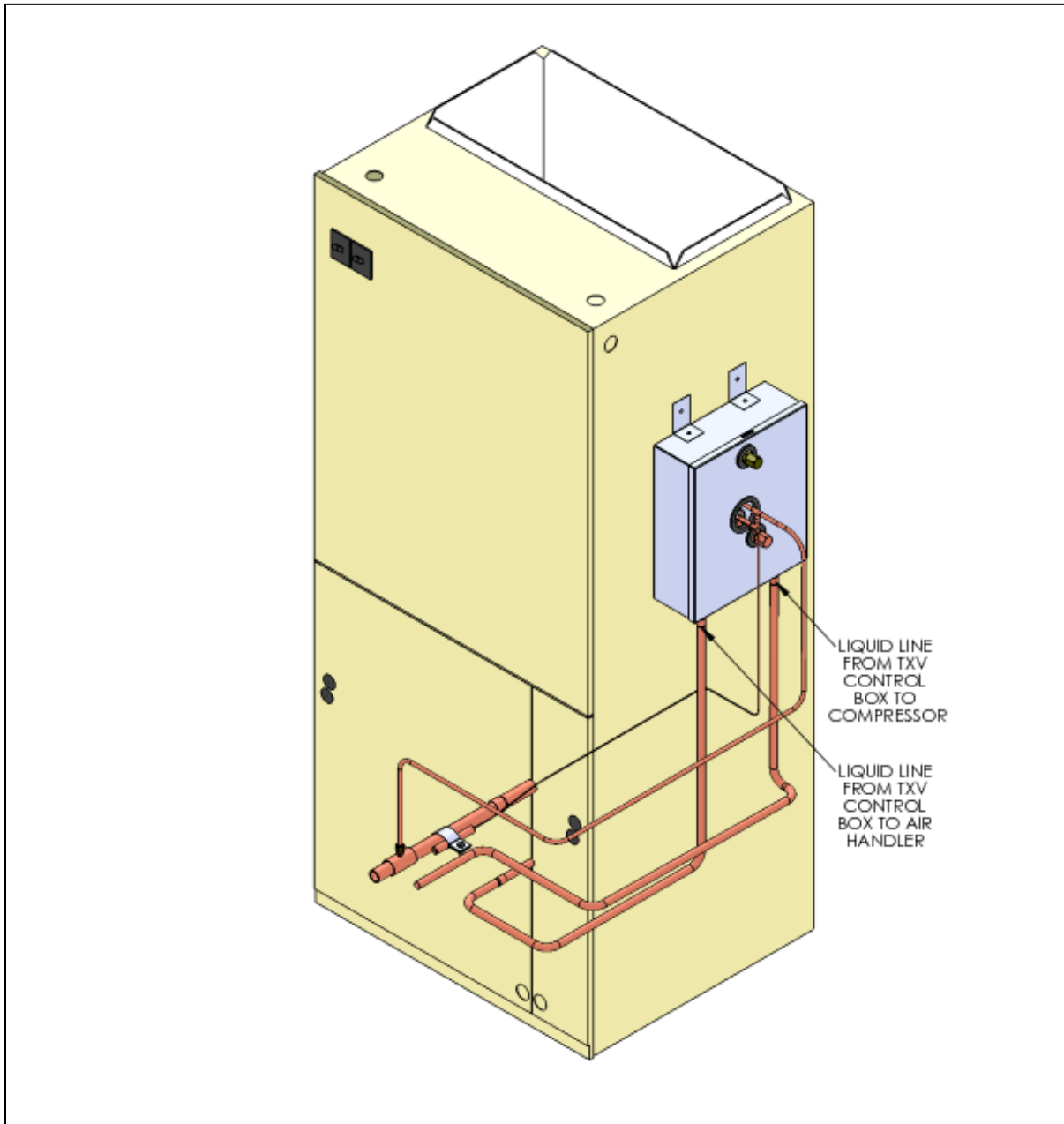
**Figure 11. Clamping the Thermal Bulb**



**Figure 12. Insulating the Thermal Bulb**

**Step 5:** Measure and cut copper tubing to connect the liquid line from the TXV control box to the liquid line stub out on the air handler as shown in Figures 7 and 13. Run the other liquid line from the connection on the TXV control box to the compressor unit, also shown in Figures 7 and 13. Nitrogen braze the joints.

**Step 6:** Connect the pressure equalizer tube to the Schrader valve. Do not replace the core. Tighten the flare connection firmly. **Wrap the liquid and vapor tubing including the liquid line tubing to the TXV control box, with Armaflex<sup>®</sup>, Insul-Tube<sup>®</sup> or equivalent insulation of at least ½" wall thickness, between the air handler and compressor unit.**



**Figure 13. TXV Liquid Line Connections**

## Electrical Data

Electrical data are illustrated in Figure 14 for all AVS Series Air handlers. **Supplemental electric strip heat is field specified, installed, and activated for heating systems upon installation.**

## Thermostat Connections

These connections are shown for typical SC system with air heating and cooling in Figure 15.

## Wiring Diagram

The AVS Series air handler wiring diagram is illustrated in Figure 16. For supplemental electric strip heat installation, see instructions enclosed with the specific kit ordered.

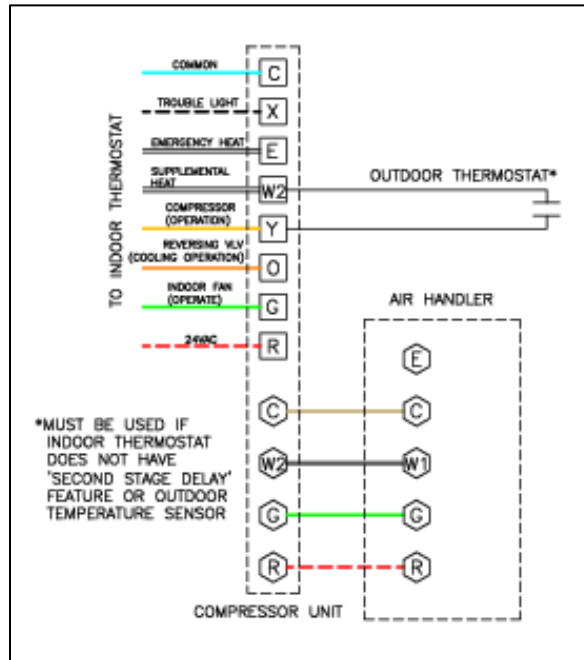
## Speed Taps & Air Flow

Speed tap settings for the AVS Series Air Handlers and the associated air flows at specific external static pressures are listed in Figure 17.

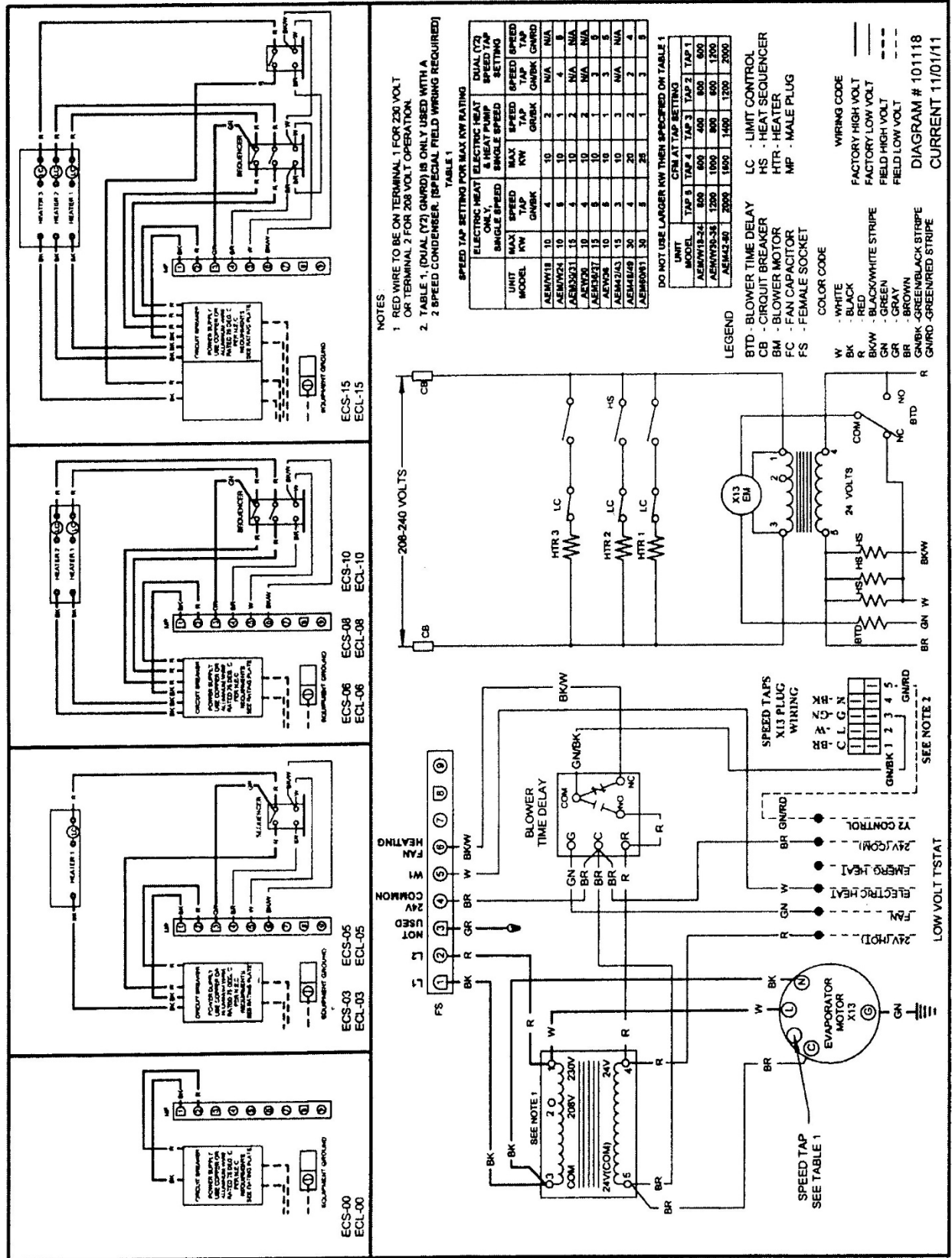
Air Handler Models	Electric Heat** kW (240V)	MCA* @ 240V	OCP @ 240V
AVS-030-CV, AVS-036-CV	0	3.3	15
	5	29	30
	8***	45	50
	10	55	60
AVS-048-CV	0	5.5	15
	5	32	35
	10	58	60
	15	84	90
AVS-060-CV	0	5.5	15
	5	32	35
	10	58	60
	15	84	90
	20	110	110

\*MCA = Minimum Circuit Ampacity. OCP = Overcurrent Protection Device, must be HACR type circuit or time delay fuse.  
 \*\*For 208 Volt, use .75 correction factor for kW.  
 \*\*\*Not Stocked. Special Order Electric Heater.

**Figure 14. AVS Electrical Data**



**Figure 15. AVS Thermostat Connections [SC(A) Compressor Unit]**



NOTES  
 1. RED WIRE TO BE ON TERMINAL 1 FOR 230 VOLT OR TERMINAL 2 FOR 208 VOLT OPERATION.  
 2. TAP 1, (DUAL (72) GNRD) IS ONLY USED WITH A 2 SPEED CONDENSER. (SPECIAL FIELD WIRING REQUIRED)

TABLE 1  
 SPEED TAP SETTING FOR MAX KW RATING

UNIT MODEL	ELECTRIC HEAT ONLY		ELECTRIC HEAT & HEAT PUMP		DUAL (72) SPEED TAP SETTING	
	MAX KW	SPEED TAP	MAX KW	SPEED TAP	MAX KW	SPEED TAP
AENW118	10	4	10	2	N/A	N/A
AENW124	10	5	10	1	4	8
AENW131	15	4	10	2	N/A	N/A
AENW138	10	4	10	2	N/A	N/A
AENW145	10	5	10	1	3	6
AENW152	15	2	10	3	N/A	N/A
AENW159	20	2	20	2	2	4
AENW166	25	2	25	2	2	4

DO NOT USE LARGER KW THAN SPECIFIED ON TABLE 1

LEGEND  
 BTD - BLOWER TIME DELAY  
 CB - CIRCUIT BREAKER  
 BM - BLOWER MOTOR  
 HTR - HEATER  
 FS - FAN CAPACITOR  
 FC - FEMALE SOCKET

LC - LIMIT CONTROL  
 HS - HEAT SEQUENCER  
 HTR - HEATER  
 MP - MALE PLUG

COLOR CODE  
 W - WHITE  
 BK - BLACK  
 R - RED  
 BKW - BLACK/WHITE STRIPE  
 GN - GREEN  
 GR - GRAY  
 BR - BROWN  
 GNBK - GREEN/BLACK STRIPE  
 GNRD - GREEN/GROUND STRIPE

WIRING CODE  
 --- FACTORY HIGH VOLT  
 - - - FACTORY LOW VOLT  
 - - - FIELD HIGH VOLT  
 - - - FIELD LOW VOLT

DIAGRAM # 101118  
 CURRENT 11/01/11

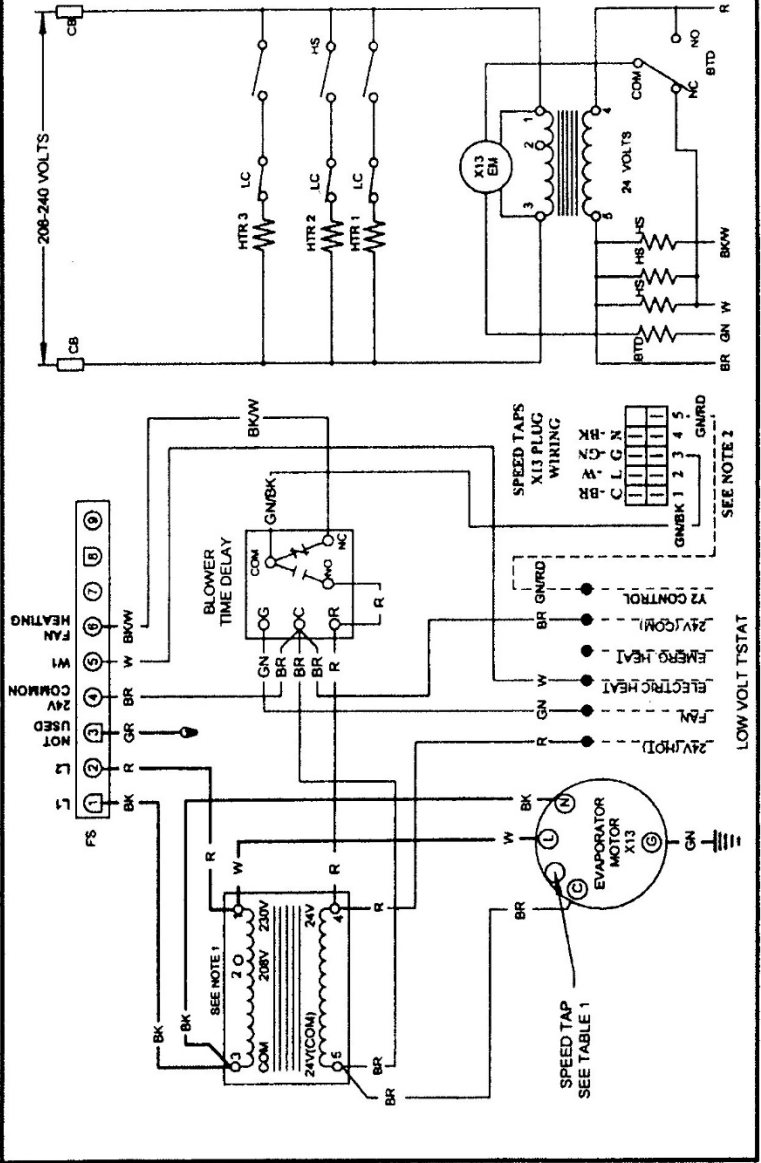


Figure 16. AVS Wiring Diagram

Models	Speed Tap	230 Volt						
		CFM V. External Static Pressure - WC						
		0.10	0.20	0.30	0.40	0.50	0.60	0.70
AVS-030-CV, AVS-036-CV	Tap 5	1291	1280	1252	1227	1200	1171	
	Tap 4	1122	1091	1066	1034	1000	982	
	Tap 3	898	873	853	827	800	786	
	Tap 2	745	698	668	630	600	558	
	Tap 1	1291	1280	1252	1227	1200	1171	
AVS-048-CV, AVS-060-CV	Tap 5	2018	1987	1961	1922	1889	1856	1823
	Tap 4	1738	1696	1667	1636	1598	1566	1527
	Tap 3	1546	1521	1482	1439	1396	1360	1321
	Tap 2	1367	1342	1303	1260	1217	1181	1142
	Tap 1	2018	1987	1961	1922	1889	1856	1823

**Figure 17. AVS Speed Taps and Air Flow Data**



## **Appendix A – Supplemental Installation Instructions**

- 1. Installation Preparation**
  - a. Clearances**
  - b. Installation Options**
  - c. Condensate Drain Pan Preparation**
  - d. Condensate Drain**
  - e. Ductwork**
- 2. Installation**
- 3. Air Handler Orientation**
- 4. Connecting Ducting**
- 5. Electrical Installation**
- 6. Condensate Drain**
- 7. Operation and Maintenance**
- 8. Final System Checkout**

## 1. Installation Preparation

Read all the instructions in this guideline carefully while paying special attention to the WARNING and CAUTION alerts. If any of the instructions are unclear, clarify with certified technicians. Gather all the tools needed for successful installation of the unit prior to beginning the installation.

### 1a. Clearances

This unit is designed for zero clearance installation on three sides and adequate clearance to provide access for service in the front. A minimum of 2.5 – 3.5 feet clearance is recommended on the front end (Fig 4A-1).

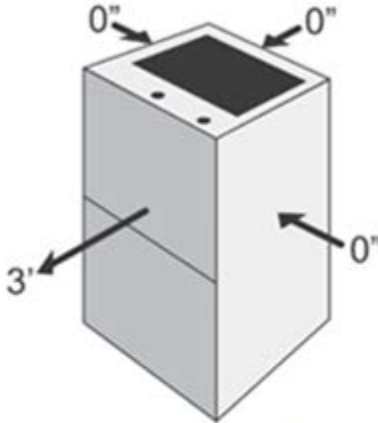


Fig 4A-1. Minimum Clearance for Air Handler

### 1b. Installation Options

If the unit is to be installed in garages, warehouses or other areas where they may be subjected to physical damage, adequate protective barriers must be installed. Unit **MUST** be installed 18" away from source of ignition.

If the unit is located in high humidity areas like attics or unconditioned garage; the air handler casing might experience nuisance sweating. In such installation scenarios, wrapping the casing with a 2" fiberglass insulation with vapor barrier **SHOULD** be used.

### 1c. Condensate Drain Preparation

✓ An auxiliary drain pan must be provided by the installer and placed under the entire unit with a separate drain line that is properly sloped and terminated in an area visible to the home owner. The auxiliary pans provide extra protection to the area under the unit should the primary and secondary drain plug up and overflow. As expressed in our product warranty; **ASPEN WILL NOT BE BILLED FOR ANY STRUCTURAL DAMAGES CAUSED BY FAILURE TO FOLLOW**

**THIS INSTALLATION REQUIREMENT.** The drains from the auxiliary drain pan must be installed according to the local building codes.

### 1d. Condensate Drain

**CAUTION** Drain lines from the auxiliary drain pan should **NOT** be connected to the primary drain line of the coil.

The drain lines must be installed with 1/4" per foot pitch to provide free drainage. A condensate trap **MUST** be installed on the primary drain line to ensure proper drainage of the condensate. The trap must be installed in the drain line below the bottom of the drain pan (Fig. 4D-1)

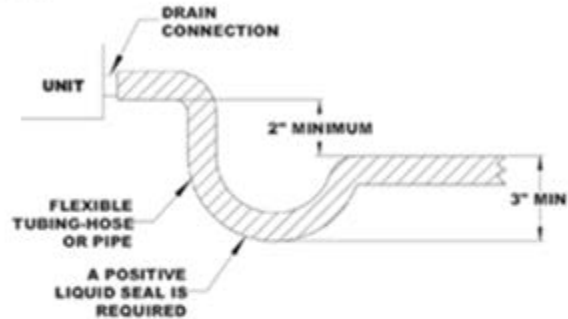


Fig 4D-1. Condensate Drain Trap

**CAUTION** Since coil is upstream of the blower, all drains **MUST** be trapped or sealed. Failure to do so will result in condensate overflow from the drain pan. Aspen will **NOT** be responsible for any damages resulting from failure to follow these instructions.

**CAUTION** If the drain pan is constructed of nylon or plastic; use Teflon tape to connect the drain lines to the threads in the drain pan. **DO NOT USE SOLVENT BASED PIPE DOPE. THIS WILL REDUCE THE LIFE OF THE PAN.**

The drain pan has primary (white) and secondary (red) drain connections. If a secondary drain line is required, it should be run separately from the primary and should terminate in a highly visible location. Condensate disposal through the secondary drain line indicates that the primary drain line is plugged and needs cleaning. If a secondary drain line is plugged, plug the secondary drain. Drain plugs are **NOT** to be reused without plumbers tape or putty. The drain line connectors should be hand tightened to a torque of approximately 35-40 lb (4-5 turns).

### 1e. Ductwork

Ductwork for air conditioning systems should be installed in accordance with standards of the National Fire Protection Association Pamphlet No. 90A or 90B, and also be sized in accordance with National Environmental System Contractors Association Manual K, whichever is applicable.

On any job, non-flammable flexible collars should be used for the return air and discharge connections to prevent transmission of vibration. Although these units have been specially designed for quiet vibration-free operation, air ducts can act as soundboards, and if poorly installed, amplify the slightest vibration to the annoyance level.

All main supply and return air drops should be properly sized as determined by the designer of the duct system and should not necessarily be the size of the duct flange openings of the unit.

When installing a central air return grille in or near the living space, it is advisable to design the ductwork so that the grille is not in direct line with the opening in the unit. The use of one or two elbows and acoustical duct liner will also ensure quieter system operation.

It is recommended that wherever supply and return air sheet metal duct pass through unconditioned areas, they be insulated to prevent excessive heat loss during heating operation. When applied in conjunction with summer air conditioning, sheet metal duct routed through unconditioned areas should be insulated and have an outside vapor barrier to prevent formation of condensation.

## 2. Installation



### CAUTION

Ensure that the unit is adequately sized. The tonnage of the outdoor unit should never exceed the tonnage of this unit.



### WARNING

The coil was manufactured with a dry nitrogen pre-charge. Release the pressure through the Schrader valve test port prior to installation. If holding pressure is not present, return coil to distributor for exchange.



### CAUTION

Some Aspen coils may include a Schrader valve on the suction manifold. Ensure that the Schrader valve and valve core (where present) are protected from heat during brazing and installation to prevent leakage. Use a core removal tool to temporarily remove the core when brazing. Replace the core once brazing is completed.

✓ Clean coil fins with degreasing agent or mild detergent and rinse fins clean prior to installation.

✓ The refrigerant line sizes should be selected according to the recommendations of the outdoor unit manufacturer.

✓ Care must be taken to ensure all connection joints are burr-free and clean. Failure to do so may increase chances of a leak. It is recommended to use a pipe cutter to remove the spun closed end of the suction line.

✓ To reduce air leakage, rubber grommets may be present where the lines pass through the coil case. To avoid damage, remove grommets prior to brazing by sliding over the lines. Use a quenching cloth or allow the lines to cool before reinstalling the grommets.

✓ Use of wet rags/quenching cloth is highly recommended to prevent weld-related damages to the casing and Schrader valve (if present).

## 3. Air Handler Orientation

This unit can be installed in vertical or right horizontal position without modifications. In case of a counterflow application, the horizontal drain pan **MUST** be removed. Fig. 6-1 shows the various orientations this air handler can be installed in.



### CAUTION

When the unit is used in a horizontal orientation, an auxiliary drain pan **MUST** be provided by the installer and placed under the entire unit with a separate drain line that is properly sloped and terminated in an area visible to the home owner. The auxiliary pan provides extra protection to the area under the unit should the primary and secondary drains become plugged and overflow. As expressed in our product warranty, failure to follow this installation requirement will void the product warranty. The drain from the auxiliary drain pan must be installed according to the local building codes.

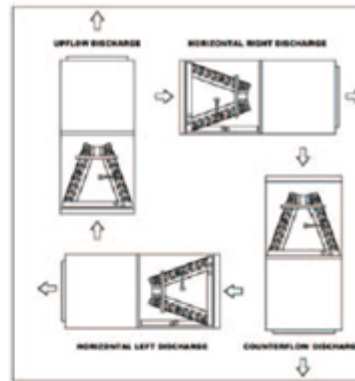
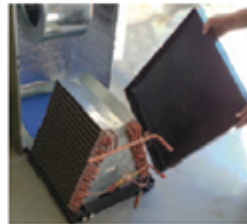


Fig 6-1

### Horizontal Left-hand Installation



1. With Air Handler in vertical position remove all access panels.



2. Remove horizontal drain pan from right hand side of coil.



3. Relocate the removed horizontal drain pan to the left side of the coil.



4. "P" traps must be installed on primary and secondary drains of the horizontal drain pan.

IO-123119 Effective 06-17-2014





5. Reinstall all access panels to the unit.



4. Remove the coil deck and filter channel, rotate the filter channels 180° and re-attach in the same location they were removed from.

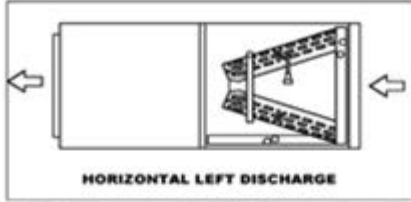


Fig 6A-1 - Air flow direction in Horizontal Left application

### Counter Flow Installation



5. Rotate the coil deck 180° and re-attach in the holes near the center of the cabinet (screws not provided).



6. Slide the A-coil assembly into the cabinet on the coil deck (without the horizontal drain pan). Note: Push the coil pan assembly all the way to the rear of the cabinet until it locks under the bracket in the rear.

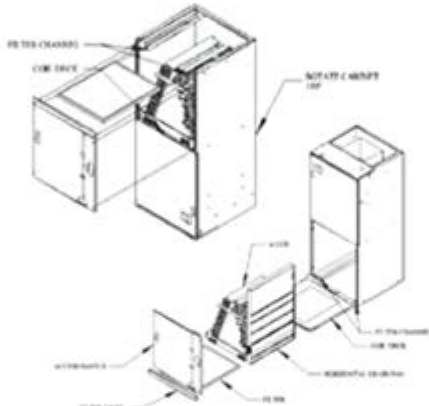


Fig 6B-1 - Air Handler Parts and Changes for Counter Flow



7. Place the 3" x 16" counter flow plates at the outside bottom of the coil as shown in Fig. 6B-3.

8. Replace the access panels and filter panel.

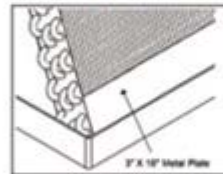


Fig 6B-3 - Position of plates required in counter flow



1. Before positioning the Air Handler in the counter flow position, remove lower access panels, filter panel and filter.



2. Remove the A-Coil assembly with the horizontal drain pan; discard the horizontal drain pan (not required for counter flow application).



3. Rotate the Air Handler 180° to the counter flow position.

### 4. Connecting Ducting

1. Secure supply air ducting to the top of the air handler. Canvas connectors are recommended for reducing potential noise transmission.
2. Secure the return air ducting to the air handler cabinet.

### 5. Electrical Installation

These units are designed for a single phase 208/240 volts, 60 Hz power supply. Wire selection and wiring must be in accordance with the National Electric Code and/or local codes. Unit terminals are designed to accommodate copper or aluminum wiring. If aluminum wiring is used; please observe special precautions relative to sizing, wire connections and corrosion protection.

Fig.11-1 shows the typical electrical connections required for A/C only and heat pump applications.

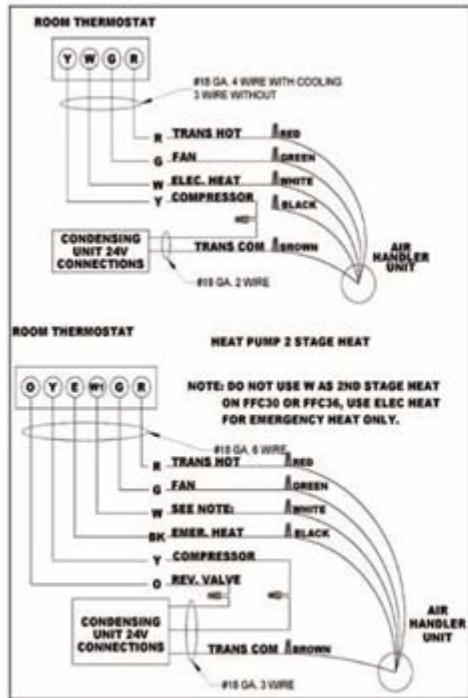


Fig 11-1.

Line voltage wiring should be routed through the access holes at the top of the air handler. Proper electrical conduit connection fittings should be used. Connect the power wiring to the line side connections on the air handler. The electrical ground wire should be connected to the grounding lug. Ensure both the field supplied ground wire and air handler GREEN ground wire are both secured to the grounding lug of the air handler (Fig 11-2).



Fig 11-2.

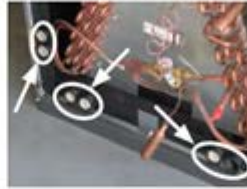
If the line voltage being supplied to the air handler is 208 volt single phase, the line voltage tap on the low voltage transformer needs to be moved from the 240 volt tap to the 208 volt tap. If this is not done, the secondary output voltage of the transformer will be too low (Fig 11-3).



IO-123119 Effective 06-17-2014

## 6. Condensate Drain

1. Select desired condensate drain openings according to air handler orientation. Both Primary and Secondary outlets can be used.
2. Pipe condensate system using proper PVC fittings.



3. Ensure a minimum 2" trap is installed in the condensate drain. Locate the trap near to the connection opening on the air handler. See illustration.

## 7. Operation and Maintenance

Below are brief descriptions of the key components of the unit and installation. This manual only provides general idea of the components and recommended practices. The installer should use best judgement to ensure safe installation and operation of the unit.

1. Room Thermostat- This is the device that controls that operation of your heating and/or cooling unit. It senses the indoor temperature and signals the equipment to start or stop maintaining the temperature you have selected for your comfort. The room thermostat should be in a central, draft free inside wall location for best operation. Do not place any heat producing apparatus such as lights, radio, etc., near the thermostat as this will cause erratic operation of the comfort system. The thermostat can accumulate dust or lint which can affect its accuracy. It should be cleaned annually.

2. Air Filter(s) - All central air moving comfort systems must include air filter(s). These filters will be located either in the equipment or in the return air duct system upstream of the equipment. The filter(s) removes dust and debris from the air thus helping to keep your air-conditioned space clean. More important, the filter keeps dust and debris from collecting on the heat transfer surfaces thus maintaining optimum equipment efficiency and performance. Inspect and clean or replace filters every month. This routine maintenance procedure will pay big dividends in reduced operating cost and reduced service expense. Never operate comfort equipment without filter(s).

3. Fuses and/or Circuit Breakers- This comfort equipment should be connected to the building electric service in accordance with local and National Electric codes. This electrical connection will include over-current protection in the form of circuit breakers. Have your contractor identify the circuits and the location of over-current protection so that you will be in a position to make inspections or replacements in the event the equipment fails to operate.



### WARNING

4. a) Do not store combustible materials or use gasoline or other flammable liquids or vapors in the vicinity of this appliance.

b) Do not operate the comfort equipment with panels removed.

c) Have your contractor point out and identify the various cut-off devices, switches, etc., that serve your comfort equipment. There is a main switch that will cut off energy to your heating system. Know where they are so that you may cut off the flow of energy in the event of overheating.

5. Periodic Checkup and Service- This product is designed to provide many years of dependable, trouble-free comfort when properly maintained. Proper maintenance will consist of annual check-ups and cleaning of the internal electrical and heat transfer components by a qualified service technician. Failure to provide periodic checkup and cleaning can result in excessive operating cost and/or equipment malfunction.

6. Lubrication- Direct drive blower motors are equipped with permanently lubricated bearings and do not require further lubrication.

7. Air filter replacement: An air filter can restrict the airflow of air to the fan coil if it is not cleaned or replaced periodically. When replacing the air filter, always replace with the same type and size as originally furnished with the unit.

## 8. Final System Checkout

1. Make certain all cabinet openings are properly sealed and any grommets moved during installation are moved into proper place.

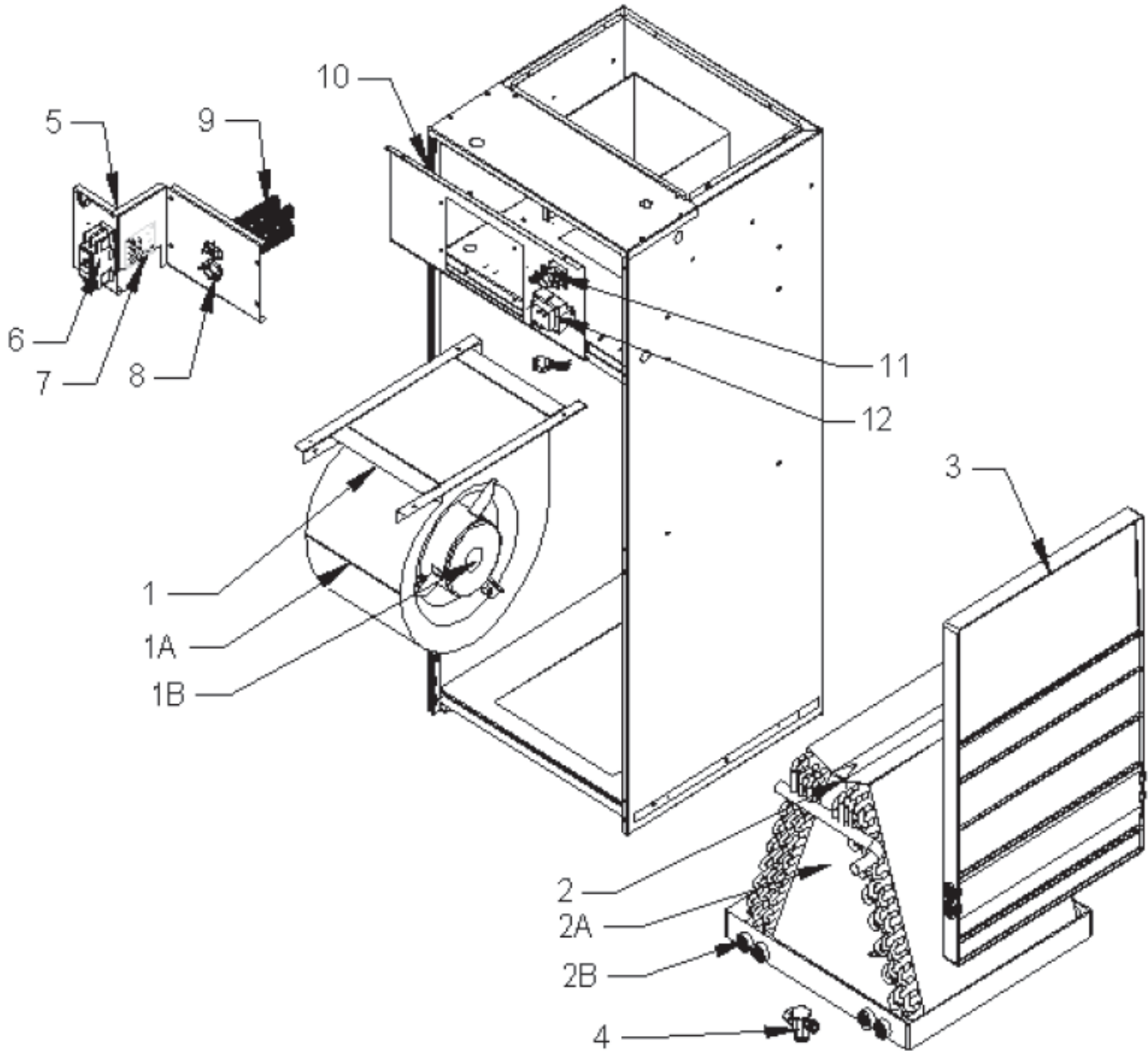
2. With cooling system operating, check for condensate leakage.

3. Perform leak detection inspection of refrigerant circuit and connecting piping.

4. Secure all cabinet doors

IO-123119 Effective 06-17-2014

## Appendix B – AVS Series (AEM) Parts List



*Note: Illustrations shown are for representation purposes only.*



Item #	Part #	Description	Unit	
1	110010	ASSY, BLOWER WHEEL & MOTOR	18 THRU 25	
	110011	ASSY, BLOWER WHEEL & MOTOR	30 THRU 37	
	110012	ASSY, BLOWER WHEEL & MOTOR	42 THRU 61	
1A	8201	BLOWER WHEEL & HOUSING	18 THRU 25	
	8200	BLOWER WHEEL & HOUSING	30 THRU 37	
	8527	BLOWER WHEEL & HOUSING	42 THRU 61	
	8202	BLOWER WHEEL & HOUSING	30 THRU 37	*
1B	8644	MOTOR, 1/3 HP, 230V	18 THRU 25	
	8646	MOTOR, 1/2 HP, 230V	30 THRU 37	
	8648	MOTOR, 1 HP, 230V	42 THRU 61	
2	129013	ASSY, A COIL WITH DRAIN PAN	18	
	129012	ASSY, A COIL WITH DRAIN PAN	24	
	129009	ASSY, A COIL WITH DRAIN PAN	30	
	129014	ASSY, A COIL WITH DRAIN PAN	36	
	129015	ASSY, A COIL WITH DRAIN PAN	42	
	129016	ASSY, A COIL WITH DRAIN PAN	48	
	129011	ASSY, A COIL WITH DRAIN PAN	60	
	129031	ASSY, A COIL WITH DRAIN PAN	19,25	
	129033	ASSY, A COIL WITH DRAIN PAN	31,37	
	129035	ASSY, A COIL WITH DRAIN PAN	43,49	
2B	129028	ASSY, A COIL WITH DRAIN PAN	61	
	8591	19" PLASTIC DRAIN PAN	18 THRU 37	
3	8593	23" PLASTIC DRAIN PAN	42 THRU 61	
	8721	17" PLASTIC HORIZONTAL PAN	18	
	8720	21" PLASTIC HORIZONTAL PAN	19 THRU 30	
	8698	25" PLASTIC HORIZONTAL PAN	31 THRU 42	
	8697	28" PLASTIC HORIZONTAL PAN	48	
4	126793	METAL PAN +6"	49 THRU 61	
	4200	NON BLEED R-410A TXV	18 THRU 37	
5	4202	NON BLEED R-410A TXV	42 THRU 61	
	126260	CIRCUIT BREAKER STAND 03-05KW	18 THRU 37	
	126261	CIRCUIT BREAKER STAND 08-10KW	18 THRU 37	
	126262	CIRCUIT BREAKER STAND 12-15KW	30 THRU 37	
	126263	CIRCUIT BREAKER STAND 00KW	42 THRU 61	
	126264	CIRCUIT BREAKER STAND 03-05KW	42 THRU 61	
	126265	CIRCUIT BREAKER STAND 08-10KW	42 THRU 61	
	126266	CIRCUIT BREAKER STAND 12-15KW	42 THRU 61	
	126267	CIRCUIT BREAKER STAND 20KW	42 THRU 61	
	126268	CIRCUIT BREAKER STAND 25KW	42 THRU 61	
	126269	CIRCUIT BREAKER STAND 30 KW	42 THRU 61	

\* - APPLICABLE ON 30, 36 AND 37 ONLY AFTER 1/1/2015

Continued on next page...

1 - APPLICABLE ON UNITS MANUFACTURED AFTER 11/1/2011

2 - ON UNITS WITH OVER 15 KW OF HEAT USE 2 EA FOR 15 & 20KW, 3 EA FOR 25 AND 30KW



Item #	Part #	Description	Unit	
6	8271	BREAKER - 15A - 2 POLE-EA	KIT ECS 00	
	8272	BREAKER - 20A - 2 POLE-EA	KIT ECS 03	
	8558	BREAKER - 25A - 2 POLE-EA	KIT ECL 03	
	8273	BREAKER - 30A - 2 POLE-EA	KIT ECS 05	
	8559	BREAKER - 35A - 2 POLE-EA	KIT ECL 05	
	8275	BREAKER - 50A - 2 POLE-EA	KIT ECS/L 08	
	8276	BREAKER - 60A - 2 POLE-EA.	KIT ECS/L 10	
7	8722	BLOWER CIRCUIT BOARD	18 THRU 61	1
	8231	BLOWER TIME RELAY	18 THRU 61	
8	8694	TEMPERATURE LIMIT - 170° F	18 THRU 61	
9	ECXXX	HEATING ELEMENTS SEE MODEL #	18 THRU 61	
10	126680	ASSY, ELEMENT INSERT	18 THRU 37	
	126656	ASSY, ELEMENT INSERT	42 THRU 61	
11	8232	HEAT SEQUENCER	05 THRU 10KW	2
12	8246	TRANSFORMER, 230V, 40VA	18 THRU 61	
13	3999	PISTON .055	AEM 18	
	4000	PISTON .059	AEM 24/25	
	3987	PISTON .068	AEM 30	
	4001	PISTON .074	AEM 36/37/38	
	3990	PISTON .080	AEM 42	
	3991	PISTON .084	AEM 48	
	3998	PISTON .092	AEM 60	
NOT SHOWN	126695	FILTER DOOR	18 THRU 37	
	126665	FILTER DOOR	42 THRU 61	
	126599	DOWNFLOW COIL KIT	18 THRU 61	
	127028	WIRING HARNESS, FEMALE SOCKET	18 THRU 61	
	127030	WIREING HARNESS MALE PLUG	NO HEAT KIT	
	127038	WIRE HARNESS X13 MOTOR MAIN	18 THRU 61	
	127041	WIRE HARNESS X13 SPEED TAP	DUAL SPEED	
	8532	MOTOR MOUNT BAND	18 THRU 61	
	8563	MOTOR MOUNT LEGS	18 THRU 37	
	8533	MOTOR MOUNT LEGS	42 THRU 61	

\* - APPLICABLE ON 30, 36 AND 37 ONLY AFTER 1/1/2015

1 - APPLICABLE ON UNITS MANUFACTURED AFTER 11/1/2011

2 - ON UNITS WITH OVER 15 KW OF HEAT USE 2 EA FOR 15 & 20KW, 3 EA FOR 25 AND 30KW