

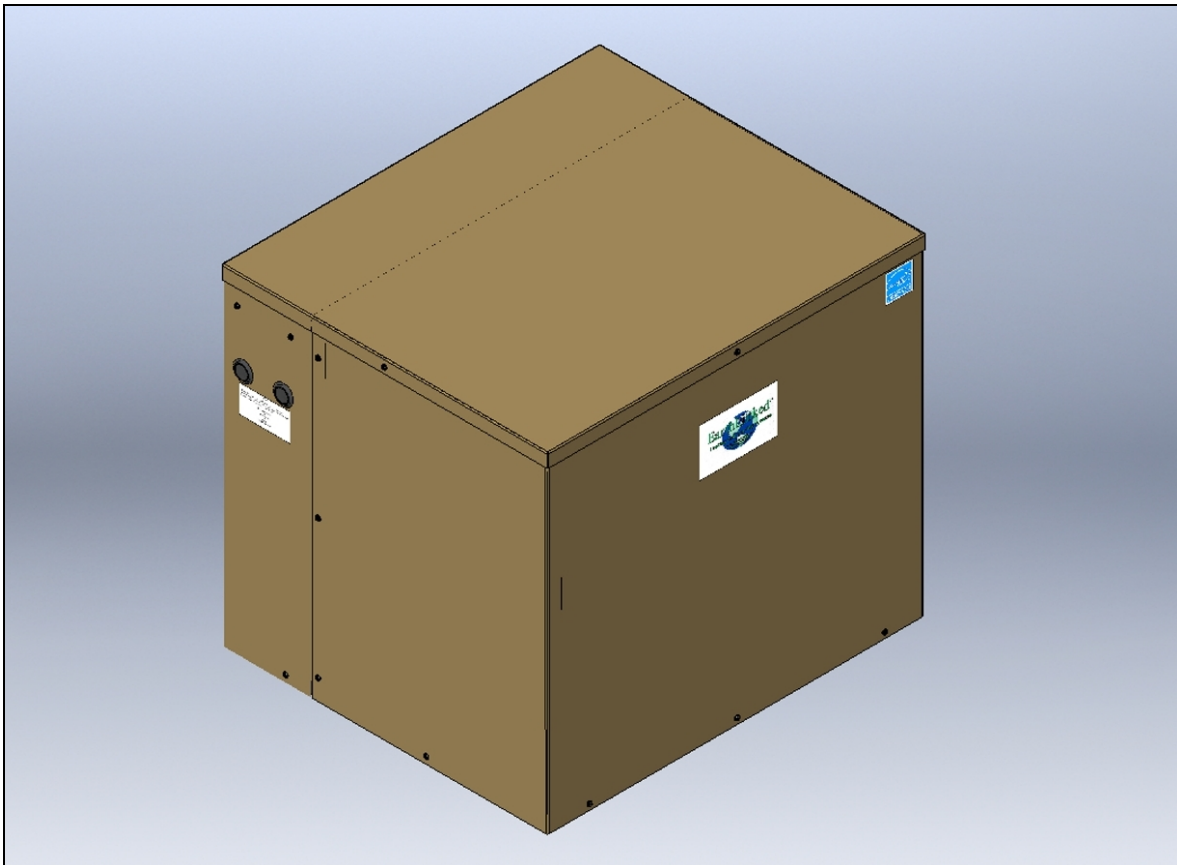

**EARTHLINKED**  
TECHNOLOGIES

**EarthLinked<sup>®</sup>**  
**HW Series Compressor Unit**  
**Quik-Start Electrical Supplement**  
for  
**50 Hertz Power**  
and  
**R-410A or R-407C Refrigerant**





### IMPORTANT

THE INFORMATION CONTAINED IN THIS MANUAL SUPPLEMENTS THE COMPRESSOR UNIT QUIK-START MANUAL. IT CONTAINS COMPRESSOR MODEL NUMBER NOMENCLATURE, ELECTRICAL DATA AND ELECTRICAL LADDER AND SCHEMATIC ILLUSTRATIONS FOR 50 HERTZ POWER SUPPLY AND R-407C REFERIGERANT SYSTEMS.

### Disclaimer

Proper installation and servicing of the EarthLinked® Heating and Cooling System is essential to its reliable performance. All EarthLinked® systems must be installed and serviced by an authorized, trained technician who has successfully completed the training class and passed the final examination. Installation and service must be made in accordance with the instructions set forth in this manual and the current *EarthLinked Heating and Cooling Installation, Operation and Maintenance Manual*. Failure to provide installation and service by an authorized, trained installer in a manner consistent with the subject manuals will void and nullify the limited warranty coverage for the system.

**READ THE CURRENT *EarthLinked Heating and Cooling Installation, Operation and Maintenance Manual* FOR COMPLETE INSTALLATION DETAILS.**

Earthlinked Technologies shall not be liable for any defect, unsatisfactory performance, damage or loss, whether direct or consequential, relative to the design, manufacture, construction, application or installation of the field specified components.



Intertek

ETL LISTED  
CONFORMS TO  
UL STD 1995  
US CERTIFIED TO CAN/CSA  
STD C22.2 NO. 236-05



COMPLIES WITH  
IEC 60204-1  
IEC 60335-2-40  
IEC 61000-3-11

Earthlinked Technologies, Inc.

4151 South Pipkin Road

Lakeland, Florida 33811

tel. 863-701-0096 • fax 863-701-7796

info@earthlinked.com • [www.earthlinked.com](http://www.earthlinked.com)

# Compressor Unit Model Numbers

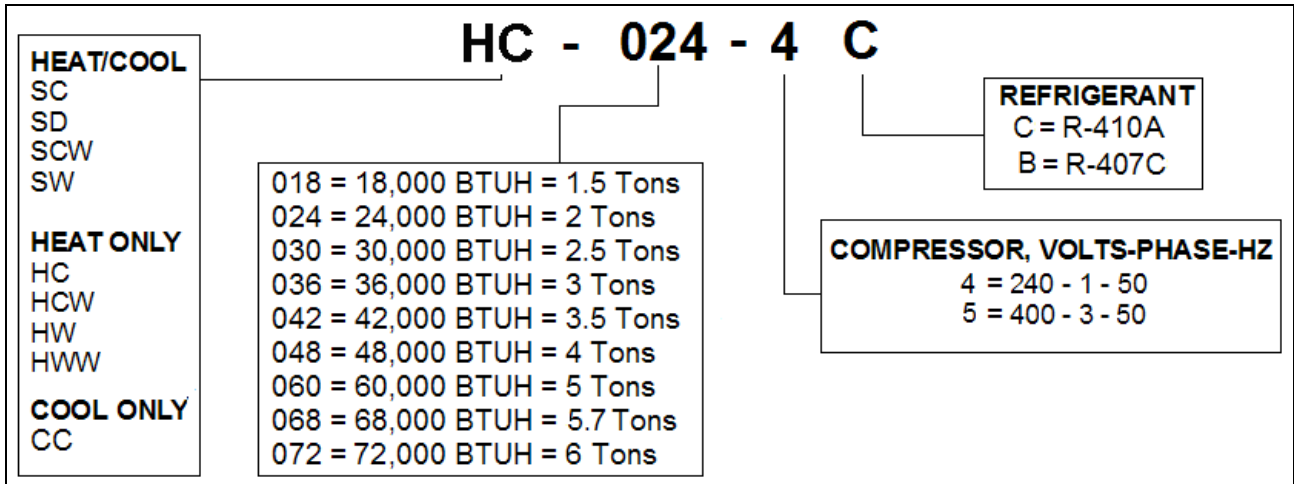

## Electrical Data – R-410A

Compressor Unit Model	Compressor Model	Voltage/Phase/Hz	Voltage		LRA	RLA	MCA	MFS
			Min.	Max.				
-018-4C	ZP24K5E-PFJ	240-1-50	216	264	60.0	12.1	15	25
-024-4C	ZP31K5E-PFJ	240-1-50	216	264	67.0	15.0	18	30
-024-5C	ZP31K5E-TFD	400-3-50	360	440	38.0	6.1	8	15
-036-4C	ZP42K5E-PFJ	240-1-50	216	264	98.0	17.7	22	35
-036-5C	ZP44K3E-TFD	400-3-50	360	440	48.0	7.9	10	15
-048-4C	ZP57K3E-PFJ	240-1-50	216	264	153.0	27.3	34	50
-048-5C	ZP57K5E-TFD	400-3-50	360	440	67.0	8.5	10	20
-060-5C	ZP72KCE-TFD	400-3-50	360	440	75.0	12.5	15	25
-072-5C	ZP83KCE-TFD	400-3-50	360	440	101.0	13.6	17	25

LRA = Locked Rotor Amps  
 RLA = Rated Load Amps  
 MCA = Minimum Circuit Ampacity

MFS = Maximum Fuse or HACR Circuit Breaker Size  
 (External)  
 AWG = Consult NEC and Local Codes



### IMPORTANT

**R-410A EARTHLINKED® SYSTEMS THAT PROVIDE HEATING REQUIRE A HEATING PERFORMANCE ENHANCEMENT KIT (HPE-1872) WHEN REQUIRED BY THE R-410A PERFORMANCE TABLES.**

## Electrical Data – R-407C

Compressor Unit Model	Compressor Model	Voltage/Phase/Hz	Voltage		LRA	RLA	MCA	MFS
			Min.	Max.				
-018-4B	ZR25K5E-PFJ	240-1-50	216	264	61	10.9	13	20
-024-4B	ZR32K5E-PFJ	240-1-50	216	264	79	12.8	16	30
-024-5B	ZR32K5E-TFD	400-3-50	360	440	38	5.8	7	10
-030-4B	ZR38K5E-PFJ	240-1-50	216	264	87	15.4	19	30
-030-5B	ZR38K5E-TFD	400-3-50	360	440	47	5.8	7	10
-036-4B	ZR48K5E-PFJ	240-1-50	216	264	133	19.2	24	35
-036-5B	ZR48K5E-TFD	400-3-50	360	440	60	7.1	9	10
-048-4B	ZR61KCE-PFZ	240-1-50	216	264	150	25.6	31	45
-048-5B	ZR61KCE-TFD	400-3-50	360	440	66	9.0	11	15
-060-4B	ZR72KCE-TFD	400-3-50	360	440	74	9.0	11	15
-072-5B	ZR81KCE-TFD	400-3-50	360	440	101	10.9	13	20

LRA = Locked Rotor Amps  
 RLA = Rated Load Amps  
 MCA = Minimum Circuit Ampacity  
 MFS = Maximum Fuse or HACR Circuit Breaker Size (External)  
 AWG = Consult NEC and Local Codes



**IMPORTANT**

**R-407C EARTHLINKED® SYSTEMS THAT PROVIDE HEATING REQUIRE A HEATING PERFORMANCE ENHANCEMENT KIT (HPE-1872) WHEN (1) IN COMMERCIAL COOLING LOAD APPLICATIONS OR (2) WHERE LOCAL EARTH TEMPERATURE IS 70°F OR ABOVE.**

# HW Compressor Unit

## 240-1-50 Ladder

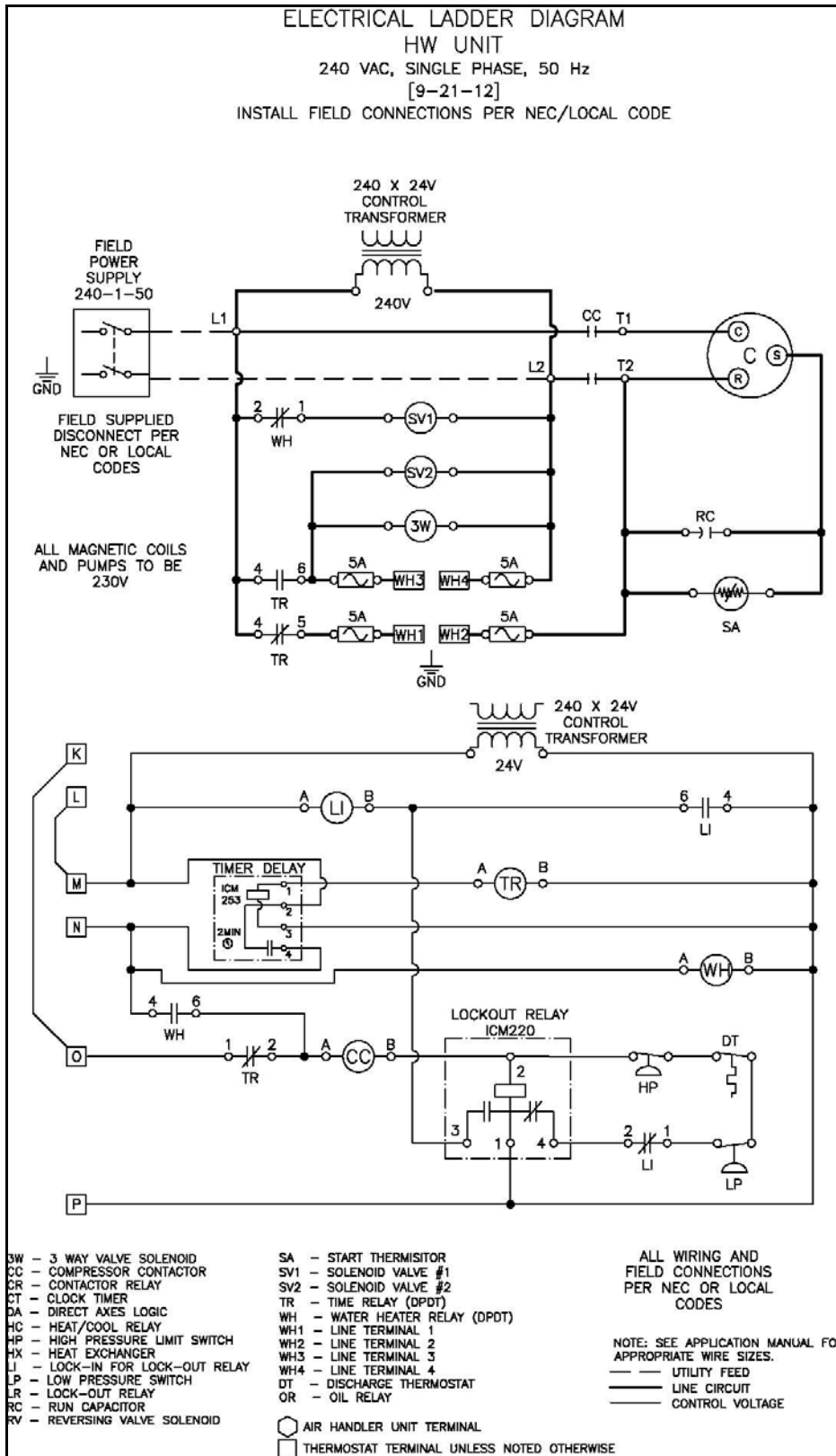

# HW Compressor Unit

## 240-1-50 Schematic

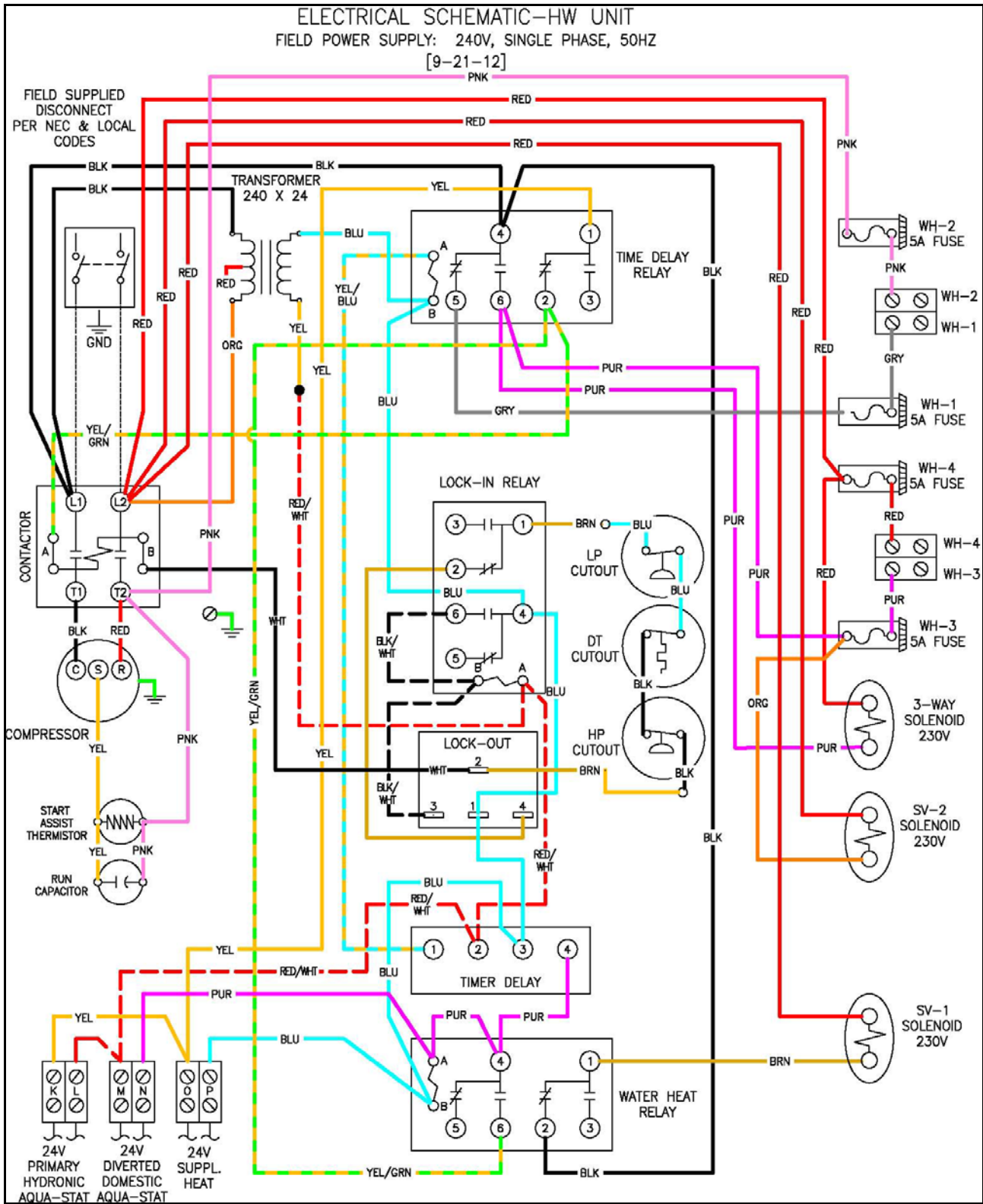

# HW Compressor Unit

## 400-3-50 Ladder

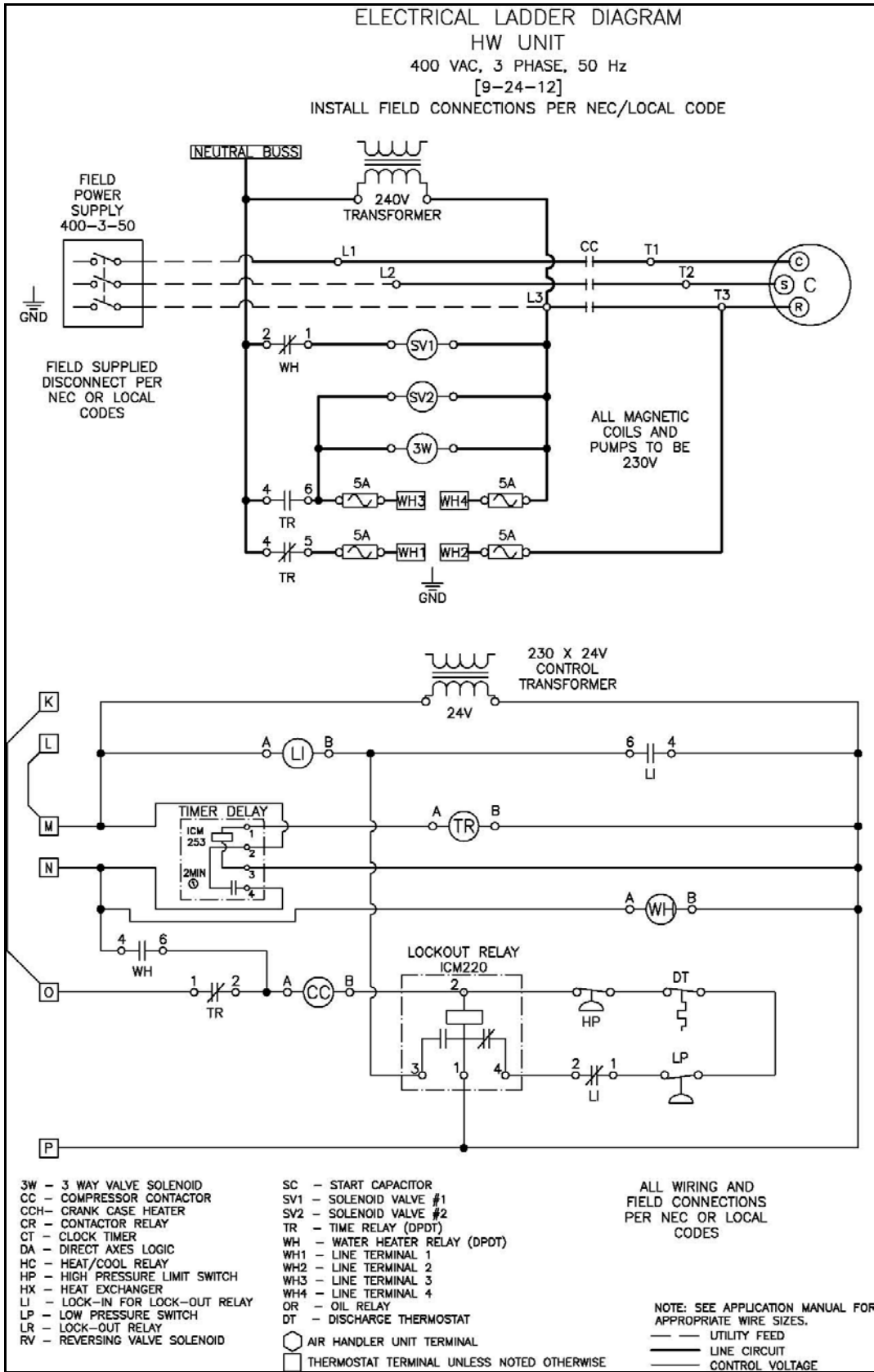



# HW Compressor Unit

## 400-3-50 Schematic

