



TECHNICAL BULLETIN

Overview:

The PSC and PSD quick-start manuals, active between March 2016 and December 2016, have been featuring the incorrect rail in the drawings. The internal flow schematics and piping diagrams were based on the Classic Series rail instead of on the Prime Series rail. As a result, the Initial Charging Port was shown in the incorrect place. Drawings have been corrected in the latest manuals, published at the end of December 2016.

The corrected drawings are shown below.

Correct Drawings:

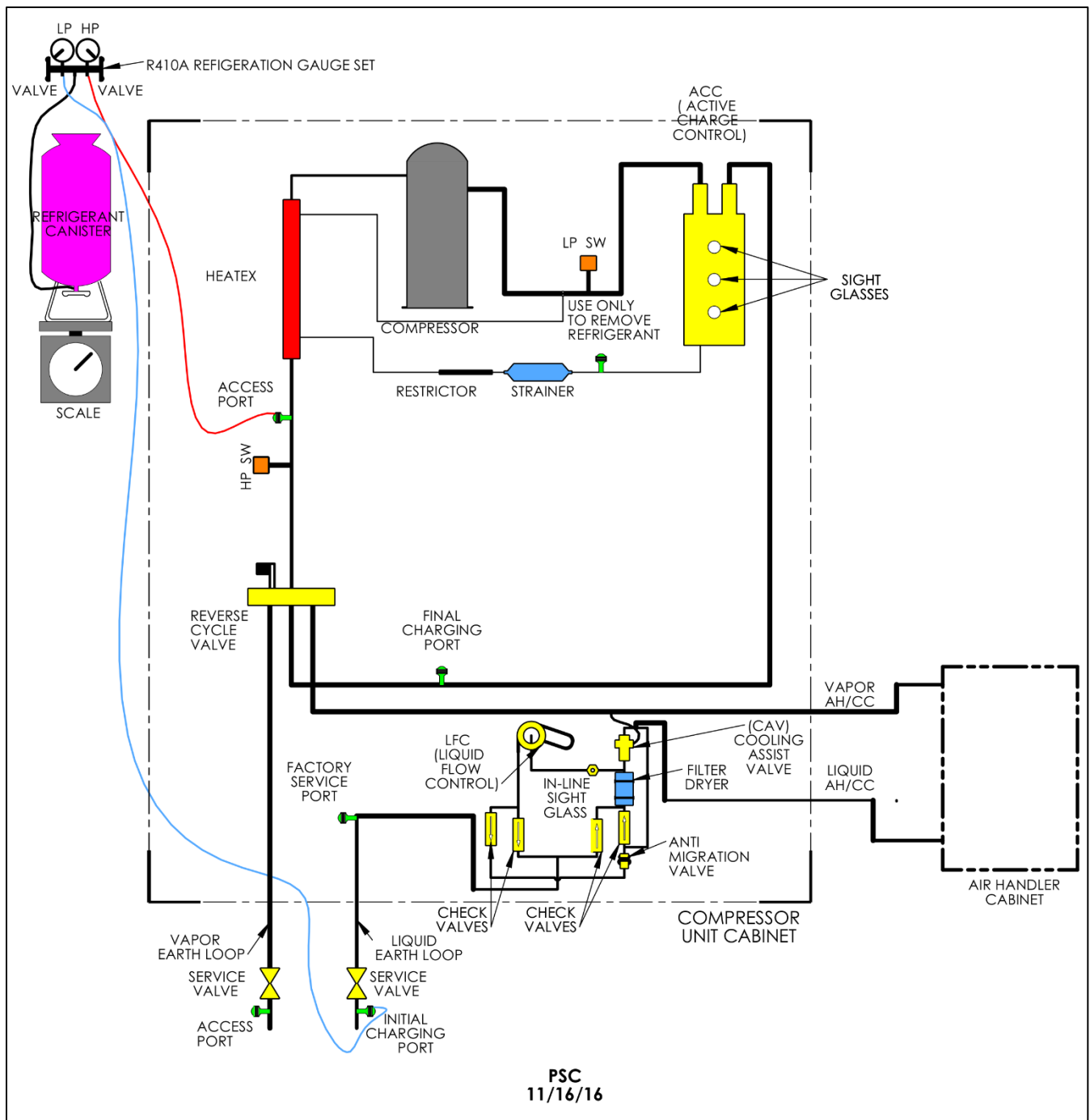
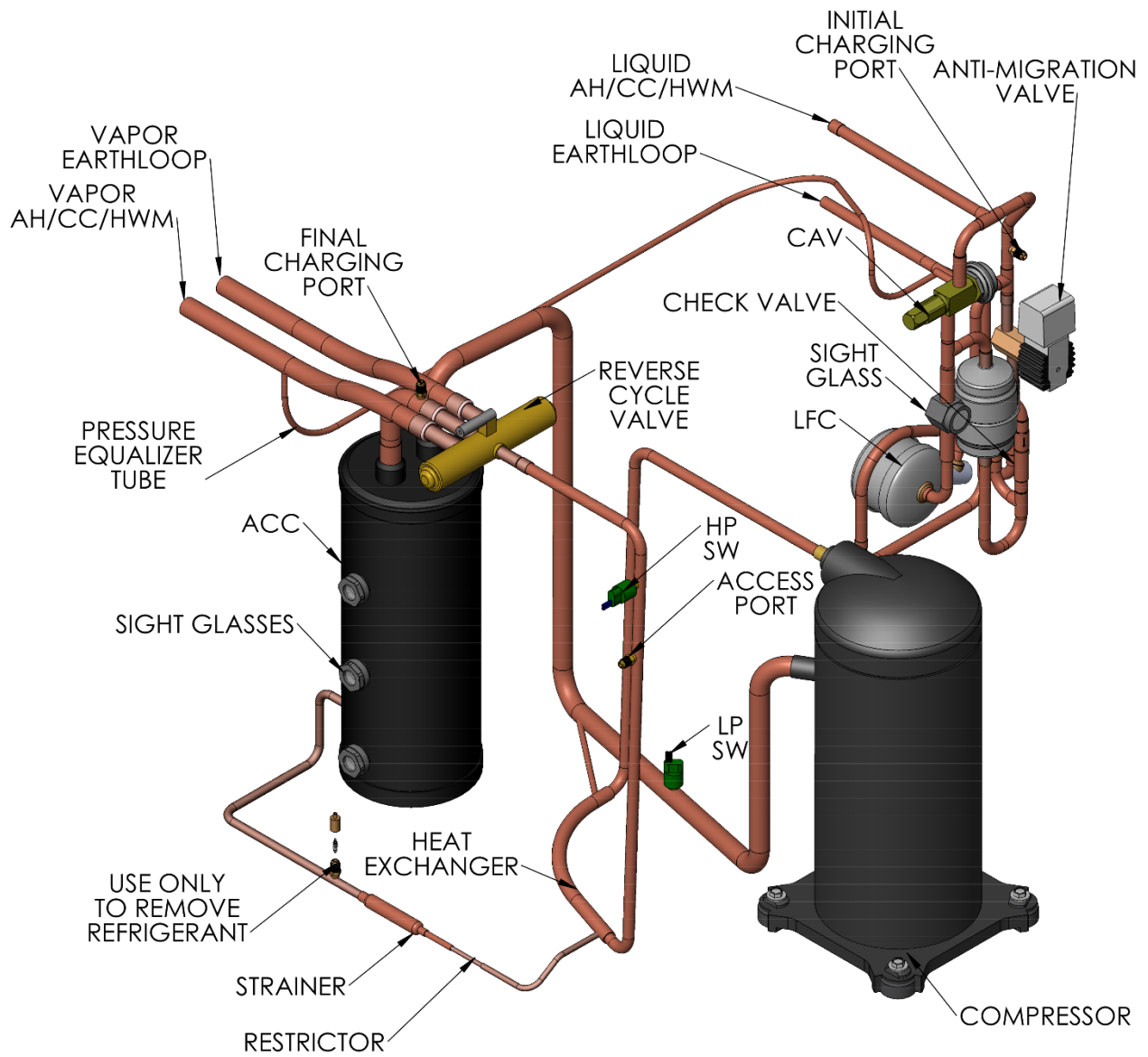

Figure 1. Initial Charge of PSC System

MODEL PSC
COMPRESSOR UNIT PIPING
10/27/16



**TUBING LENGTHS
NOT TO SCALE**

Figure 2. PSC Piping

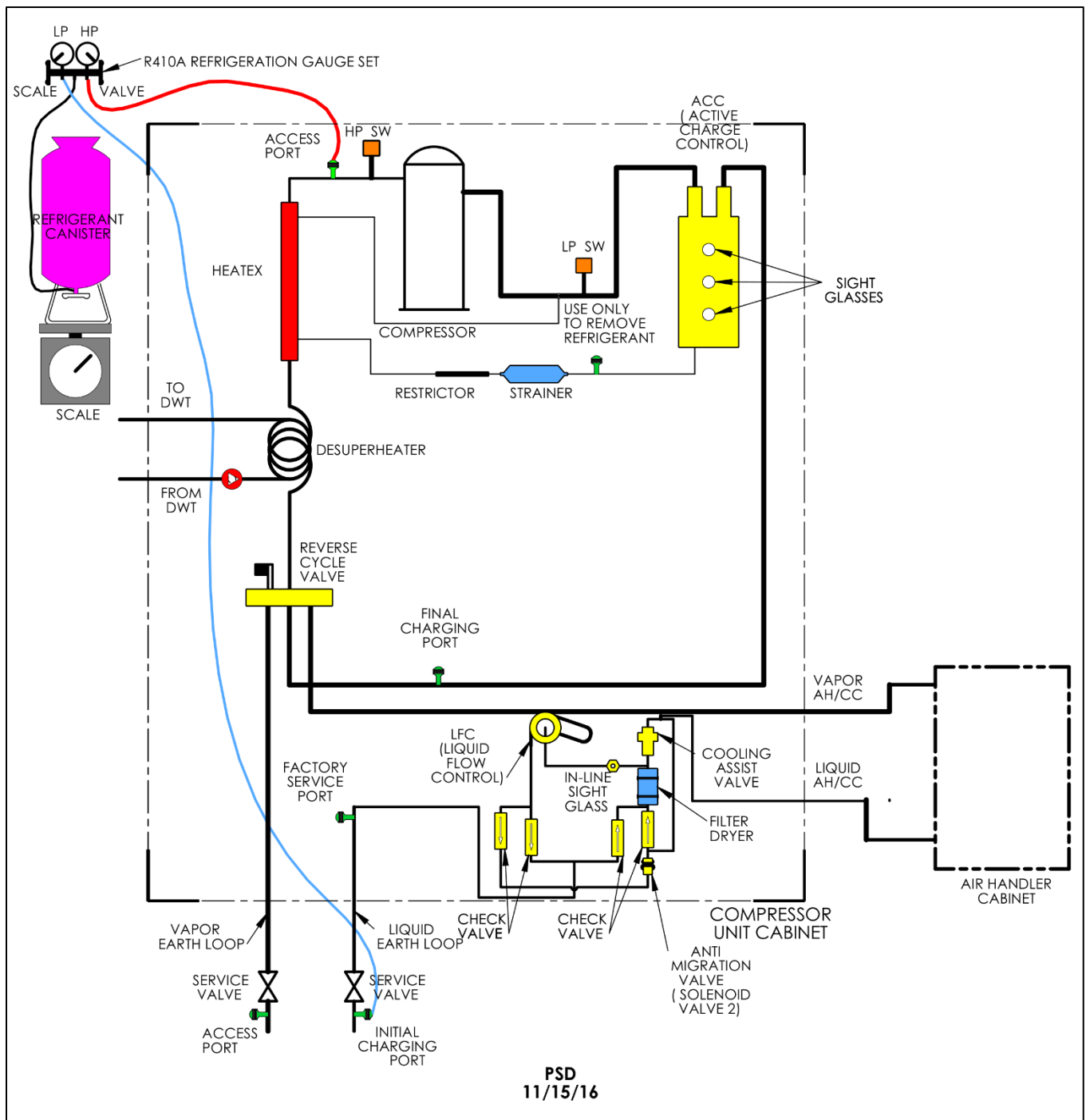

Figure 3. Initial Charge of PSD System

MODEL PSD COMPRESSOR UNIT PIPING

11/15/16

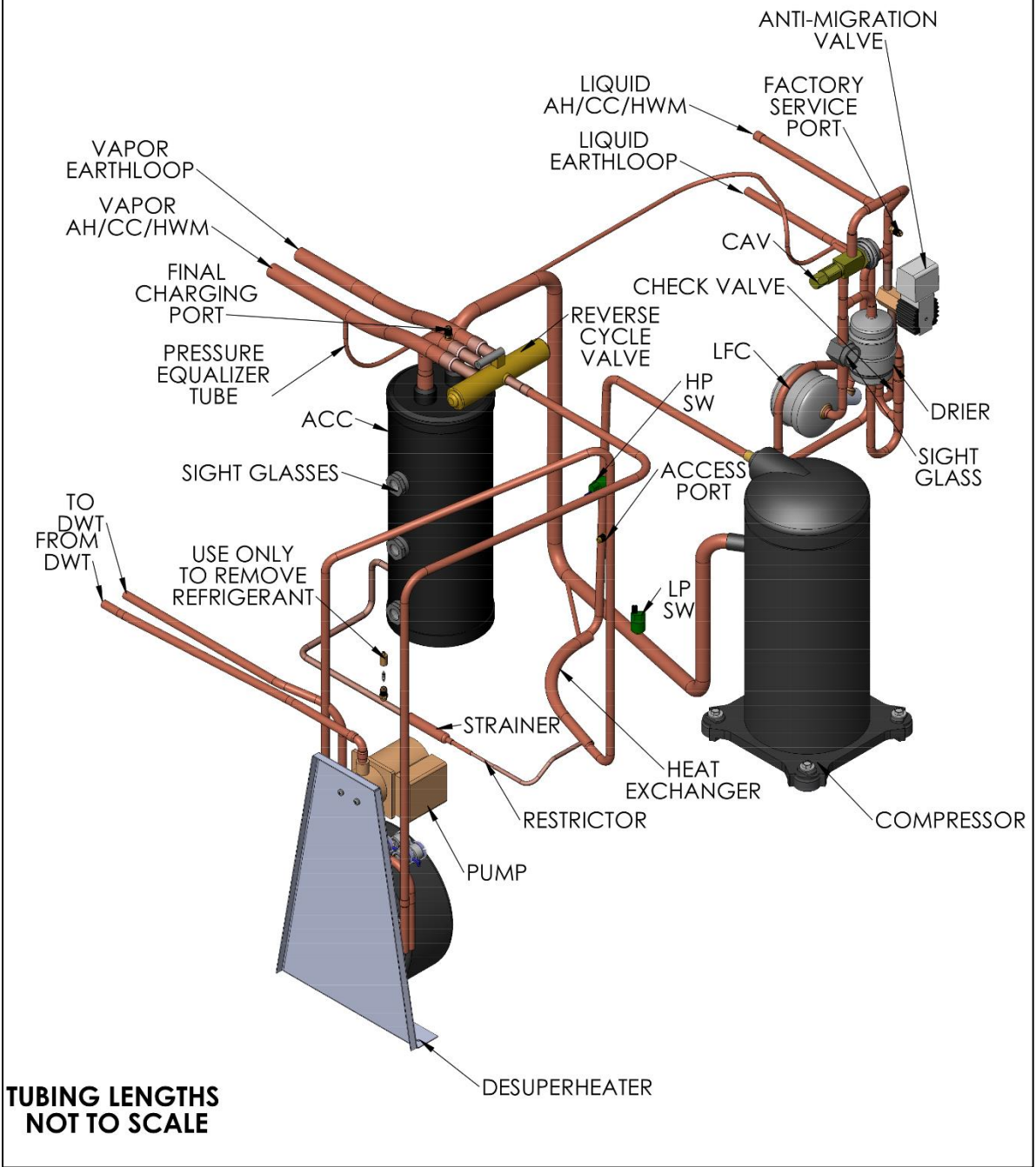

Figure 4. PSD Piping

Contact: For further assistance, call ETI Technical Service at 1-863-701-0096 and refer to Tech Bulletin #012717.