

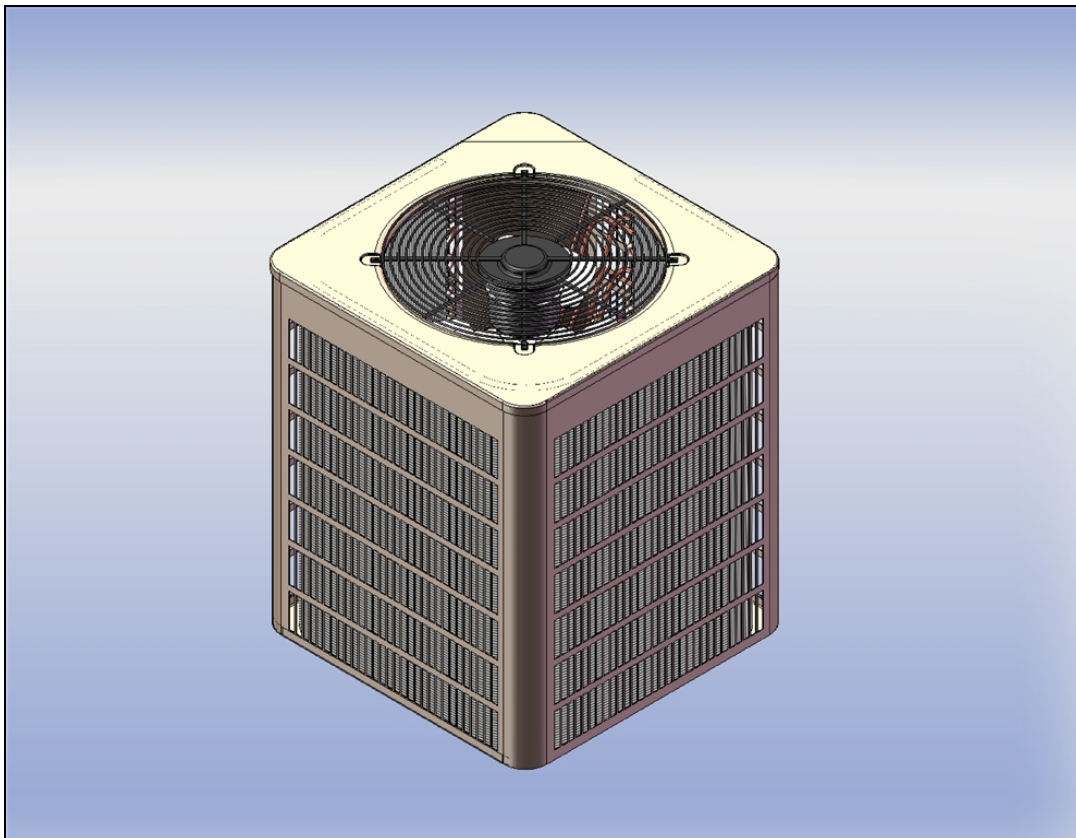

EARTH LINKED
TECHNOLOGIES

EarthLinked[®]
Auxiliary Cooling Module
Models ACM-024C thru ACM-072C
For R-410A
Installation Manual

CONTENTS	PAGE
Pre-Installation	3
Installation	5
• Placement	5
• Refrigerant Connections	7
• Electrical	10



Disclaimer

The EarthLinked® Auxiliary Cooling Module is sold as a system component part and must be properly sized and matched to the system compressor unit to provide the intended performance and safe operation of the system. This component must be installed by a trained technician who has successfully completed the ETI training class and passed the final examination. Installation must be made in accordance with the instructions set forth within this manual.

Failure to provide installation by an authorized, trained installer in a manner consistent with this manual will void the limited warranty coverage for the EarthLinked® system.

Earthlinked Technologies shall not be liable for any defect, unsatisfactory performance, damage or loss, whether direct or consequential, relative to the design, manufacture, construction, application or installation of other components in the EarthLinked® system.

Earthlinked Technologies, Inc.
4151 South Pipkin Road
Lakeland, Florida 33811
tel. 863-701-0096 • fax 863-701-7796
info@earthlinked.com • www.earthlinked.com

Pre-Installation

This EarthLinked® Auxiliary Cooling Module is approved for use with EarthLinked® space heating and cooling systems utilizing Series SC, SD, and SCW compressor units operating with R-410A refrigerant.

This Auxiliary Cooling Module is sold as a system component and must be properly matched with the compressor unit to provide the anticipated performance and safe operation of the system. The table below lists the properly matched EarthLinked® Auxiliary Cooling Module models with EarthLinked® compressor unit models.

Application of the Auxiliary Cooling Module (ACM) to R-410A systems may require the use of two (2) field supplied Type ACR copper couplings to match the ACM refrigerant tube connection size with the line set vapor tube size, See the table below to determine coupling sizes.

Auxiliary Cooling Module Model	Compressor Unit Model	Couplings OD" x OD" (2 Req'd.)
ACM-024C	-024	3/4 x 5/8
ACM-036C	-036	3/4 x 3/4
ACM-048C	-048	7/8 x 7/8
ACM-060C	-060	1-1/8 x 7/8
ACM-072C	-068	1-1/8 x 1-1/8



WARNING

Before installing this heat exchanger, be sure that all electrical power to the Earthlinked® system is "OFF".

Wear adequate protective clothing and practice all applicable safety precautions while installing this equipment. Failure to do so may result in equipment and / or property damage, personal injury or death.



WARNING

Inhalation of high concentrations of refrigerant gas vapor is harmful and may cause heart irregularities, unconsciousness or death. Vapor reduces oxygen available for breathing and is heavier than air. Decomposition products are hazardous. Liquid contact can cause frostbite. Avoid contact of liquid with eyes and prolonged skin exposure. Liquid and gas are under pressure. Deliberate inhalation of refrigerant gas is extremely dangerous. Asphyxiation can occur without warning due to lack of oxygen. Before working with a refrigerant, read the Materials Safety Data Sheet for that specific refrigerant.

The electrical and physical data for the Auxiliary Cooling Module is shown in the table below:

Auxiliary Cooling Module Electrical and Physical Data

Model	Power	Voltage Range	Min. Circuit Amps	Max. Fuse Amps*	Fan Motor			Cabinet Dimensions		
					Full Load Amps	Rated HP	Nominal RPM	Width, inches	Depth, inches	Height, inches
ACM-024C	230-1-60	207-253	0.9	5.0	0.7	1/10	1010	24.25	24.25	24.50
ACM-036C	230-1-60	207-253	0.9	5.0	0.7	1/10	1010	24.24	24.25	24.50
ACM-048C	230-1-60	207-253	0.9	5.0	0.7	1/10	1010	24.25	24.25	24.50
ACM-060C	230-1-60	207-253	1.4	5.0	1.1	1/5	1090	24.25	24.25	28.50
ACM-072C	230-1-60	207-253	1.4	5.0	1.1	1/5	1090	24.25	24.25	28.50

*Overcurrent Protection Device

Installation – Auxiliary Cooling Module Placement

The Auxiliary Cooling Module unit is placed as shown in Figure 1 relative to other components in the EarthLinked® system. **The Auxiliary Cooling Module is located outdoors and will be connected to the refrigerant line set outside the building.**

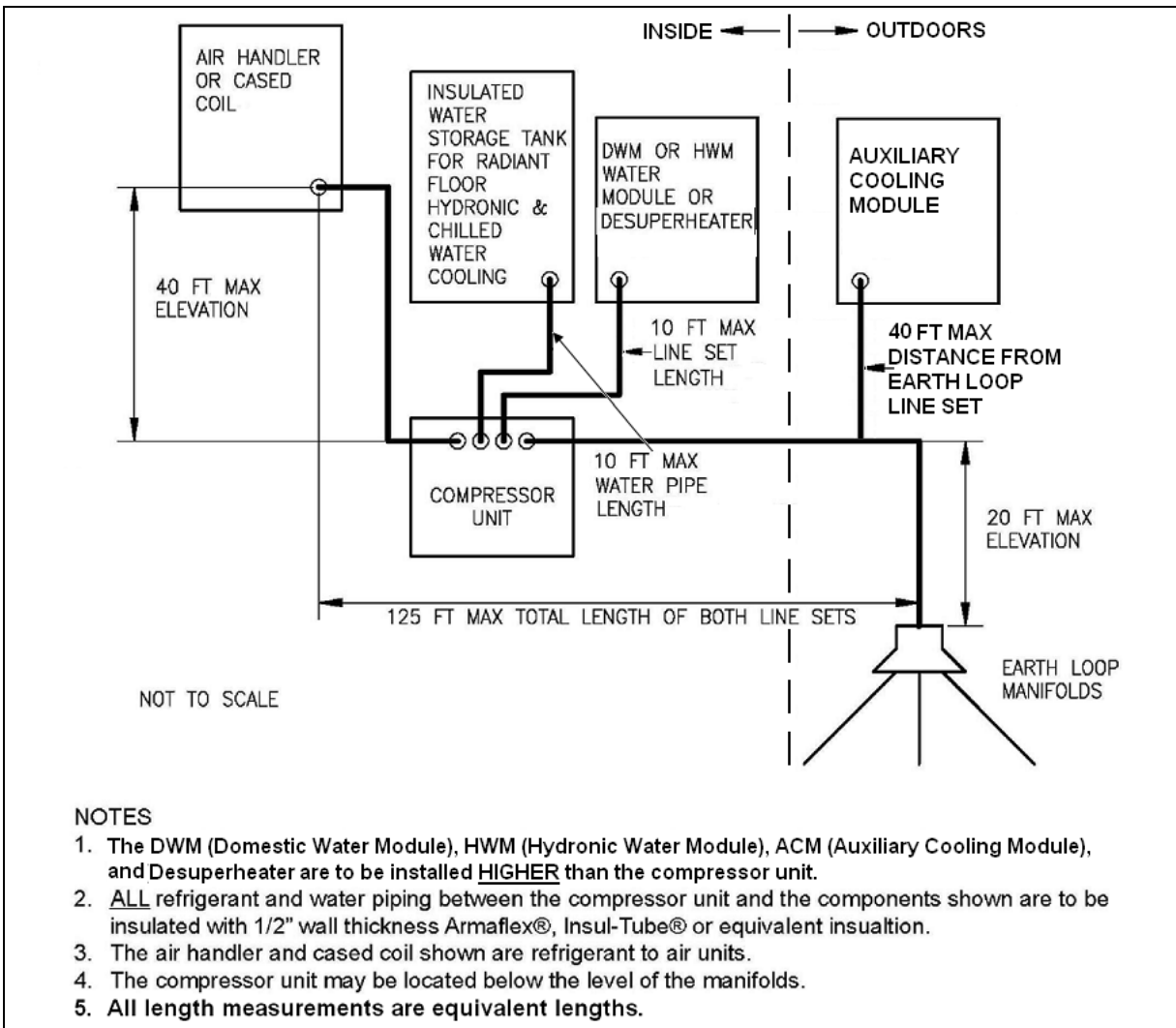

Figure 1. Auxiliary Cooling Module Placement in EarthLinked® System

Location Requirements for the Auxiliary Cooling Module:

1. Within 40 Feet of the earth loop line set. Minimize refrigerant line lengths.
2. Higher than the compressor unit.
3. No more than 20 feet higher than the earth loop manifolds.
4. With proper clearances around the unit:
 - 48 inches minimum on top
 - 12 inches minimum on the three sides
 - 24 inches minimum on the service side
5. Away from windows, patios, decks, etc., where unit operation sounds may disturb the occupants.

6. On a solid, level mounting slab. The mounting slab should extend a minimum of 2 inches beyond the sides of the Auxiliary Cooling Module. To reduce the possibility of noise transmission, the mounting slab should NOT be in contact with or be an integral part of the building foundation.
7. Where conditions or local codes require the Auxiliary Cooling Module to be attached to a mounting pad or frame, tie down bolts should be used to fasten through the knockouts provided in the Auxiliary Cooling Module basepan.
8. Elevate the Auxiliary Cooling Module per local climate and code requirements to provide clearance above estimated snowfall level and ensure adequate water drainage of Auxiliary Cooling Module. Use snow stand in areas where prolonged freezing temperatures are encountered.

Do NOT Locate the Auxiliary Cooling Module:

1. On brick, concrete blocks or unstable surfaces
2. Near clothes dryer exhaust vents
3. Near sleeping area or near windows
4. Under eaves where water, snow or ice can fall directly in the unit
5. Within clearance less than 2 Feet from a second unit
6. Within clearance less than 4 Feet on top of unit
7. Within the minimum distance the Auxiliary Cooling Module can be installed from the property line, where local zoning ordinances apply.

Installation – Refrigerant Connections

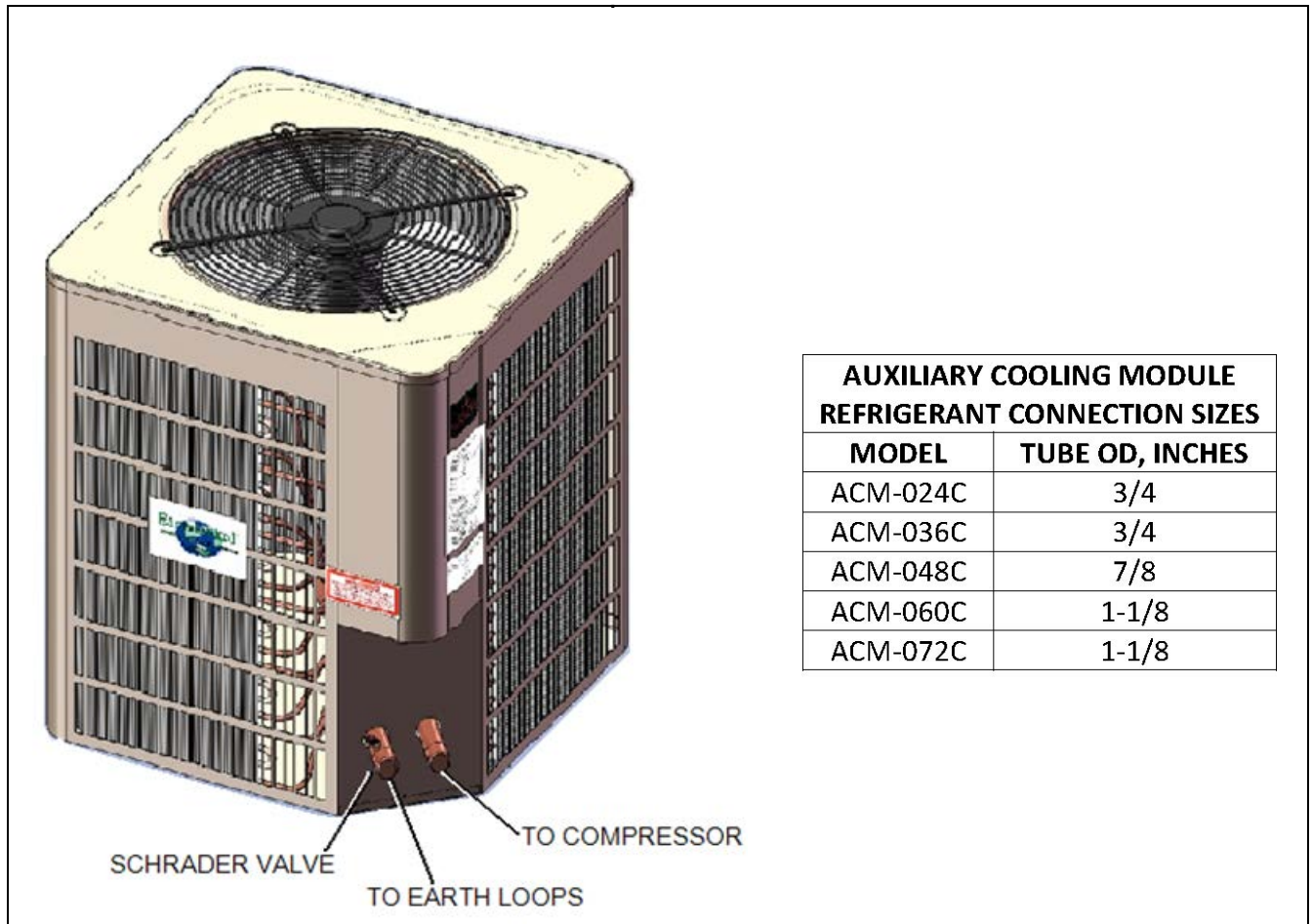

Figure 2. Auxiliary Cooling Module Refrigerant Connections

The Auxiliary Cooling Module has two refrigerant connections on the service side of the unit as shown in Figure 2. The connections are the same size as each other. These sizes are listed in Figure 2 for each Auxiliary Cooling Module model. Each connection is identified with a label saying “To compressor” or “To earth loops”.



IMPORTANT

The Auxiliary Cooling Module has a factory charge of dry nitrogen at approximately 35psig. Relieve the nitrogen from the system by means of the Schrader valve located on the refrigerant connection illustrated in Figure 2.

The refrigerant connections have caps brazed on at the factory. They should be un-brazed at the time that tubing is to be connected to the Auxiliary Cooling Module.

After locating the Auxiliary Cooling Module as noted earlier, a trench 3 to 4 Feet deep is to be excavated running from the Auxiliary Cooling Module to the earth loop line set. If the lines to and from the Auxiliary Cooling Module are to be run parallel to and within 10 Feet of the building foundation or basement wall, both lines are to be insulated with ½” wall thickness Armaflex® or InsulTube® tubing insulation, cased within a 4” PVC pipe. The PVC pipe must be a minimum of 3 Feet from the building foundation or wall. This is illustrated for a typical application in Figure 3.

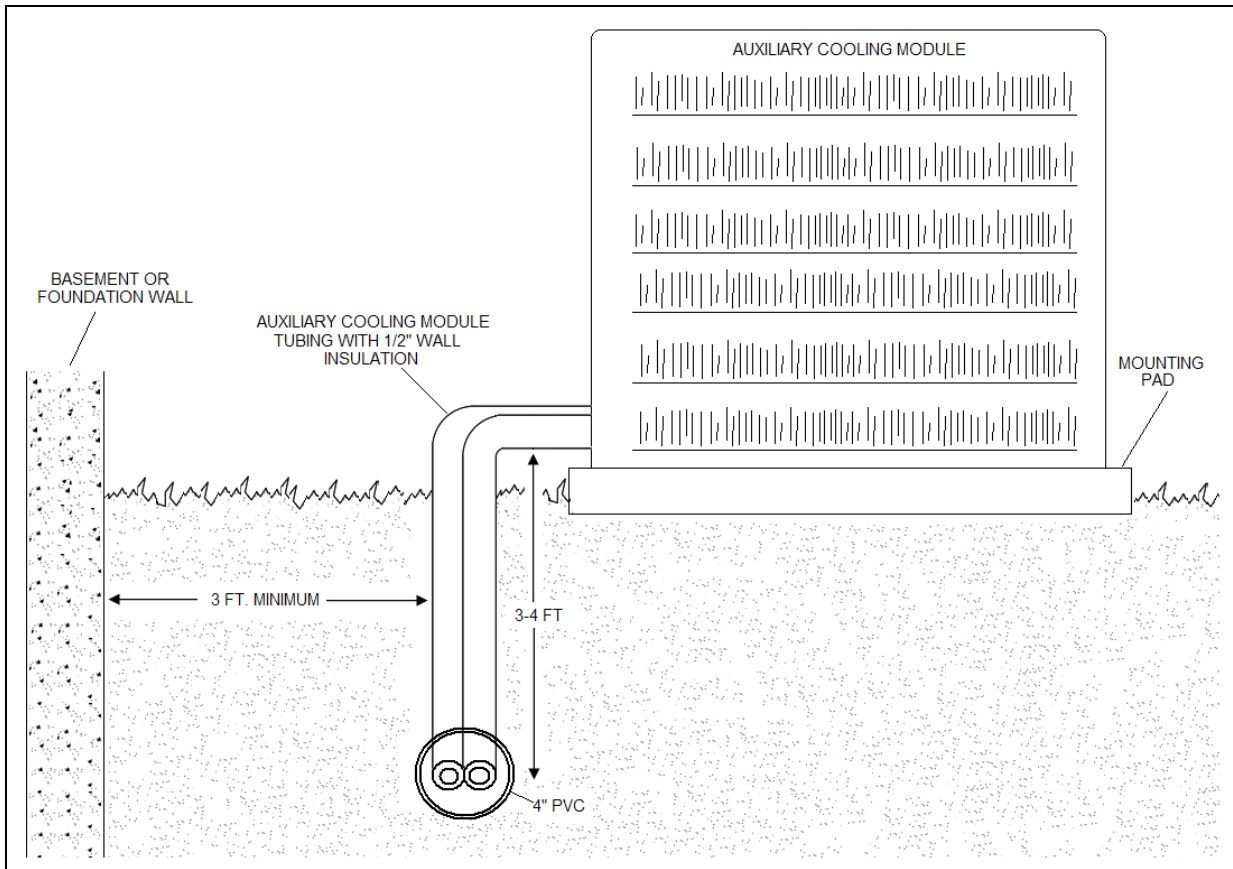

Figure 3. Auxiliary Cooling Module Refrigerant Piping

A top view of typical Auxiliary Cooling Module and line set vapor line connections are illustrated in Figure 4.

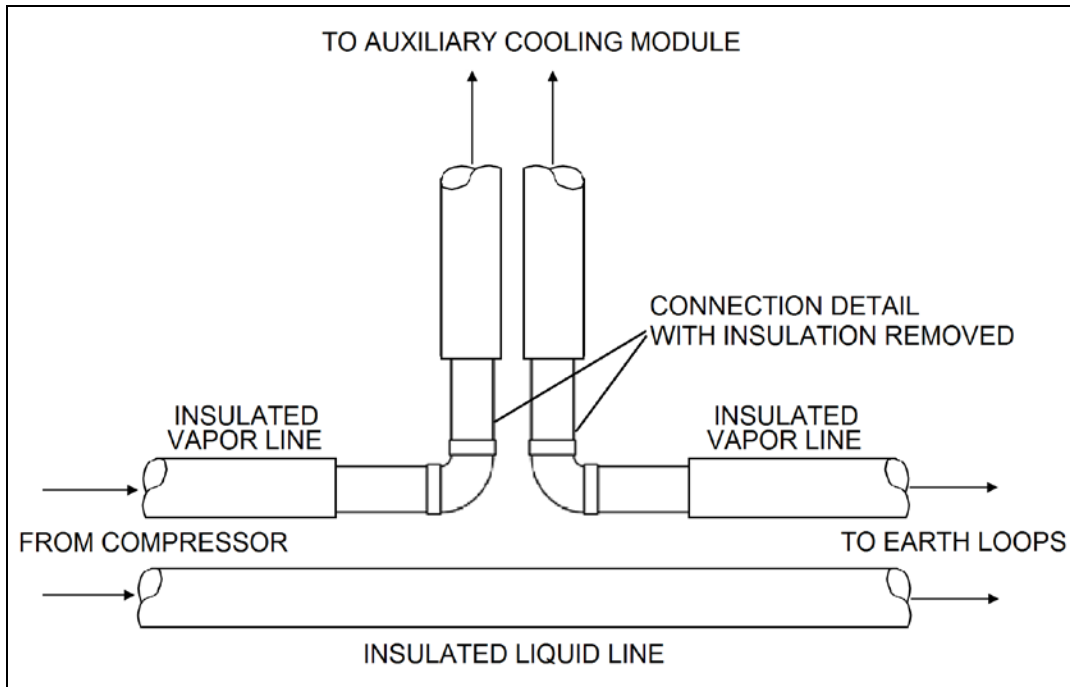

Figure 4. Top View of Line Set Connections

All refrigerant piping joints and connections in the EarthLinked® heating and cooling system, including the Auxiliary Cooling Module, line sets and earth loop system are to be brazed with 15% silver content brazing alloy, utilizing the **NITROGEN BRAZING PROCESS**.



IMPORTANT!

NITROGEN BRAZING PROCESS

PURPOSE:

Utilize the **NITROGEN BRAZING PROCESS** on all brazed refrigerant piping connections. This process eliminates oxidation products from inside joint surfaces.

TECHNIQUE:

“Trickle” nitrogen gas at 1-2 psi pressure through the joint area being brazed, to displace the oxygen. When oxygen has been displaced, turn off the nitrogen and relieve the pressure at the joint to atmospheric prior to brazing.

CONSEQUENCES:

Failure to displace oxygen with nitrogen at the brazed joint will result in particulate matter being released into the system. The result is discoloration of refrigerant oil, contamination of the system and possible system failure.

Installation - Electrical



WARNING

BEFORE REMOVING ANY ACCESS PANELS AND INITIATING ANY PHASE OF THIS INSTALLATION MAKE SURE THAT POWER IS TURNED "OFF" TO ALL EARTHLINKED® AND FIELD SUPPLIED SYSTEM COMPONENTS. FAILURE TO DO SO COULD RESULT IN PROPERTY DAMAGE, SERIOUS INJURY OR DEATH.



WARNING

WEAR ADEQUATE PROTECTIVE CLOTHING AND PRACTICE ALL APPLICABLE SAFETY PRECAUTIONS WHILE INSTALLING THIS EQUIPMENT. FAILURE TO DO SO MAY RESULT IN EQUIPMENT AND/OR PROPERTY DAMAGE, PERSONAL INJURY OR DEATH.

1. After turning "OFF" power to all EarthLinked® and field supplied system components at the appropriate breakers **remove the front and top panels of the compressor unit cabinet.**
2. Reference Figure 5 for compressor unit electrical box. Remove available hole covers from the front of the electrical box.

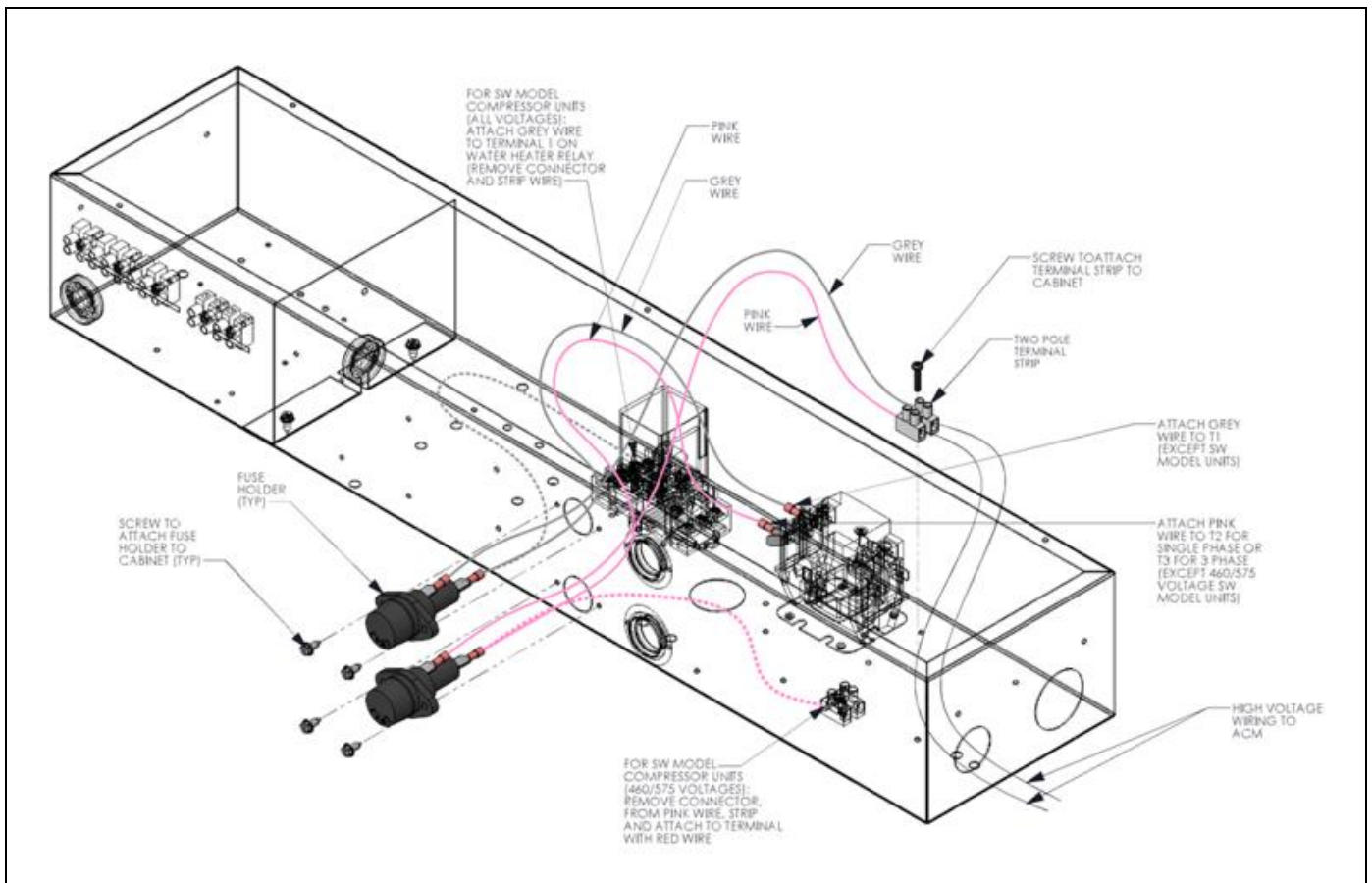

Figure 5. Compressor Unit Electrical Box

3. Install fuse holders into existing fuse holes with screws provided. Install fuses in fuse holders.

4. Install two-pole terminal strip inside electrical box and fasten into existing hole with screw provided.
5. Attach pink wire with piggyback connector onto “T2” (for single phase) or “T3” (for three phase) on the compressor contractor and the other connector to the center terminal of the bottom fuse holder.



IMPORTANT

USE PIGGY BACK TO REATTACH WIRES IF NO TABS ARE AVAILABLE FOR INSTALLING KIT.



CAUTION

DO NOT REMOVE CLIP BY PULLING ON WIRE.

DO NOT ALLOW PIGGY BACK CLIP TO TOUCH OTHER TERMINALS.

6. Attach the gray wire with the piggy back connector onto “L1” on the compressor contactor, and the other connector to the center terminal of the top fuse holder.
7. Attach the pink wire with connector to the collar connection of the bottom fuse holder, and tighten the terminal screw of the terminal block onto the stripped end of the pink wire.
8. Attach the gray wire with connector to the collar of the top fuse holder, and tighten the other terminal screw of the terminal block onto the stripped end of the gray wire.
9. Run high voltage wiring from the two-pole terminal strip in the electrical box out of the grommeted end hole of the electrical box and through the conduit connection of the compressor cabinet, to the Disconnect shown in Figure 6, and from the Disconnect to the Auxiliary Cooling Module, using flexible conduit.
10. After running the power wiring in flexible conduit to the Auxiliary Cooling Module, remove the Auxiliary Cooling Module electric box cover.



WARNING

The Auxiliary Cooling Module cabinet must have an unbroken ground. The ground must be installed in accordance with applicable electrical codes. Failure to follow this warning can result in injury, fire or death.

11. The Auxiliary Cooling Module control box contains a Ranco pressure control that has been factory set to energize the Auxiliary Cooling Module at a predetermined compressor discharge pressure.

DO NOT ATTEMPT TO ADJUST THIS CONTROL!

Figure 6 illustrates the electrical connections that are to be made at the ACM electric box with the two high voltage leads from the compressor unit.

AUXILIARY COOLING MODULE FIELD WIRING DIAGRAM

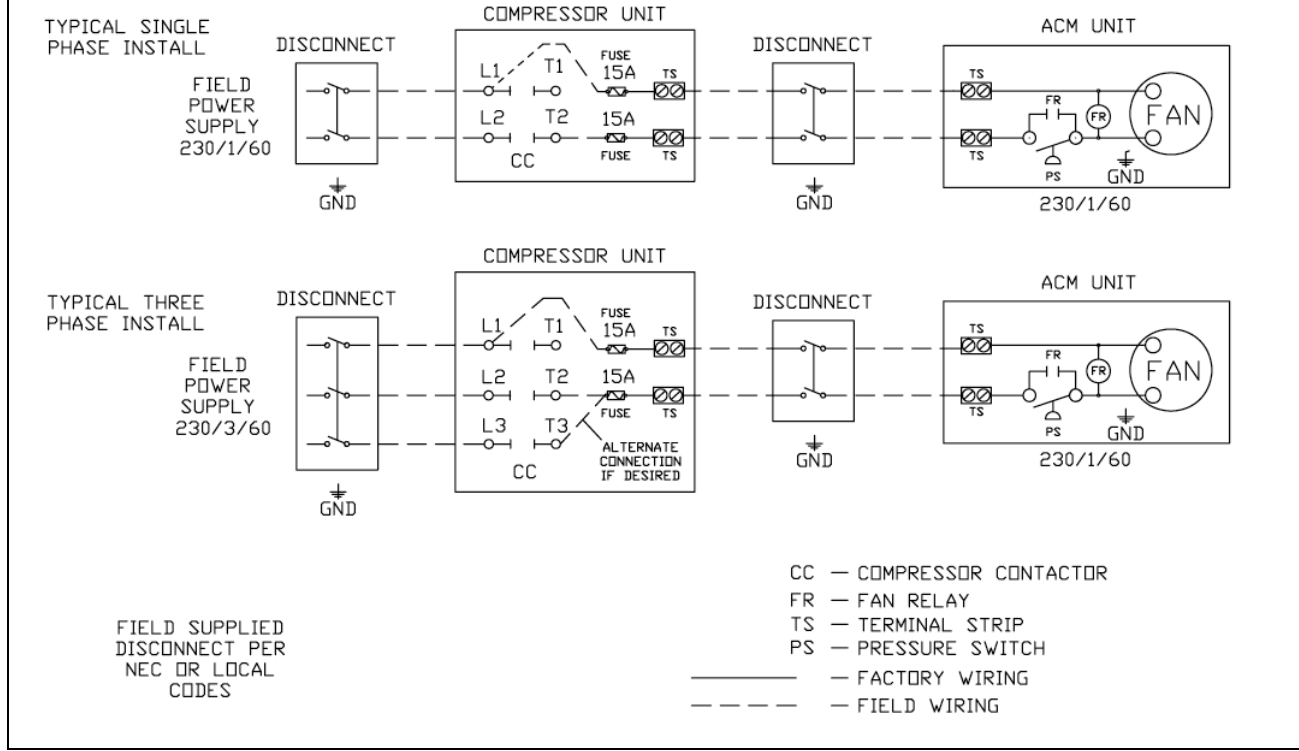

Figure 6. Auxiliary Cooling Module Field Wiring

12. **Check all wiring and electrical connections to ensure proper routing and good contact** before restoring electric power, evacuating and recharging system in accordance with the appropriate EarthLinked® system Installation Manual.