

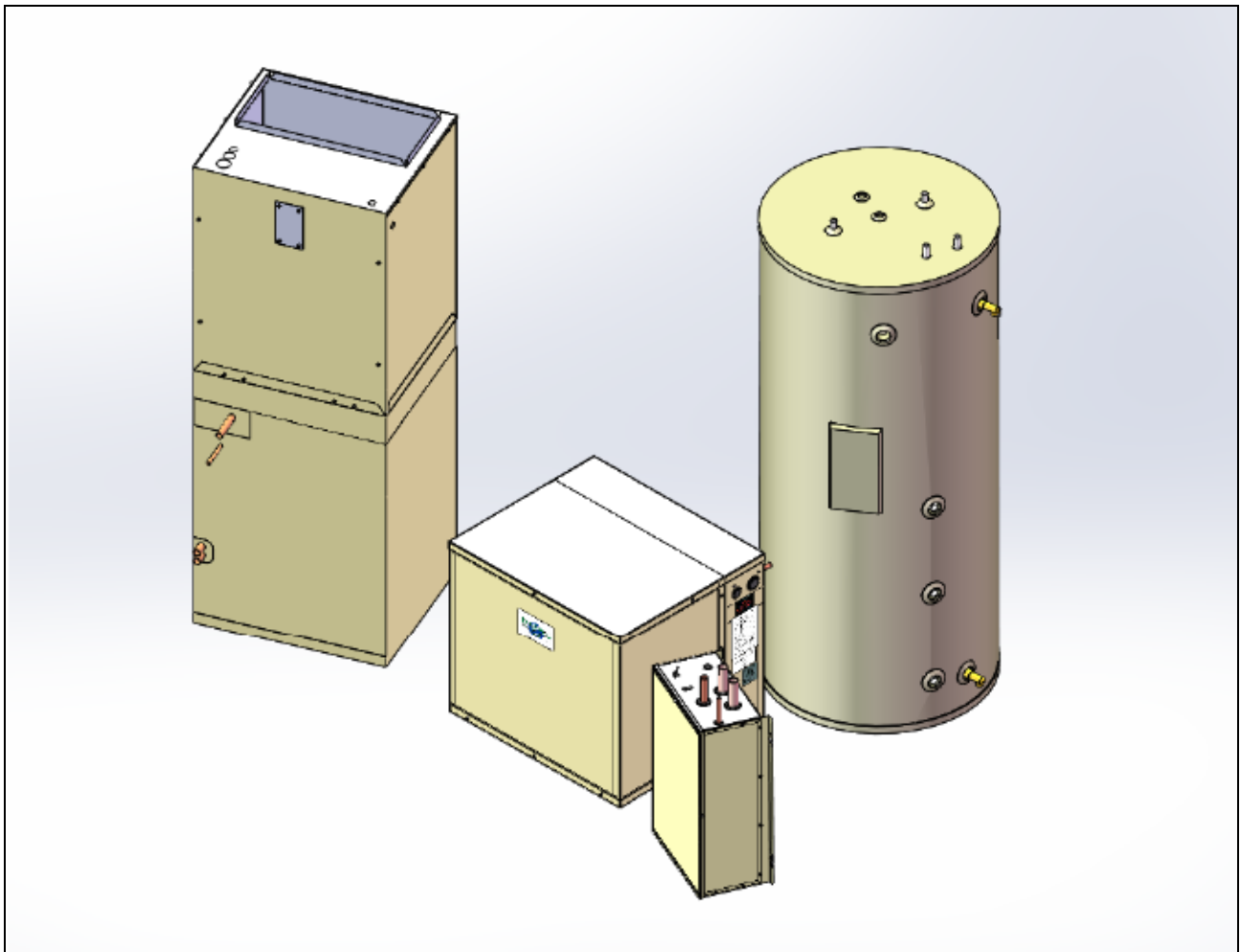

EARTHLINKED
TECHNOLOGIES

EarthLinked[®]
SC(A), SD(A), SD(H) and SCW(A)
Heating and Cooling Systems
User's Manual



This manual is the property of the owner and must be left with the equipment user.

EarthLinked® Dealer and System Information

For the purposes of preventive maintenance or service, fill in the following information about your EarthLinked® Dealer and Heating/Cooling System. Be sure the dealer completes the information on the next page describing the earth loop system.

Dealer Company Name: _____

Telephone Number: _____

Date of Installation: _____

Compressor Unit Model: _____ Serial: _____

Air Handler/Cased Coil Model: _____

Hydronic Water Module Model: _____

Earth Loop Model: _____

Earth Loop Protection System Model: _____

Auxiliary Cooling Module Model: _____

Thermostat Model: _____

Storage Water Heater Model: _____

Before Calling Your Dealer for Service:

- Check that electrical disconnect switches are “ON”.
- Replace blown fuses and reset circuit breakers.
- Check room thermostat for proper setting.
- Check air filter to ensure it is clean.
- Have model and serial numbers and installation date available.



COMPLIES WITH
IEC 60204-1
IEC 60335-2-40
IEC 61000-3-11



ETL LISTED
CONFORMS TO
UL STD 1995
US CERTIFIED TO CAN/CSA
STD C22.2 NO. 236-05



Compressor units are Energy Star
Qualified when purchased with matching
EarthLinked® air handlers or cased coils.

Using a **permanent structure** as basis for measurement, and using triangulation, determine and record **earth loop manifolds location** and the **anode location** (as appropriate) on the grid below. Show the general overall dimensioned outline of the earth loop field.

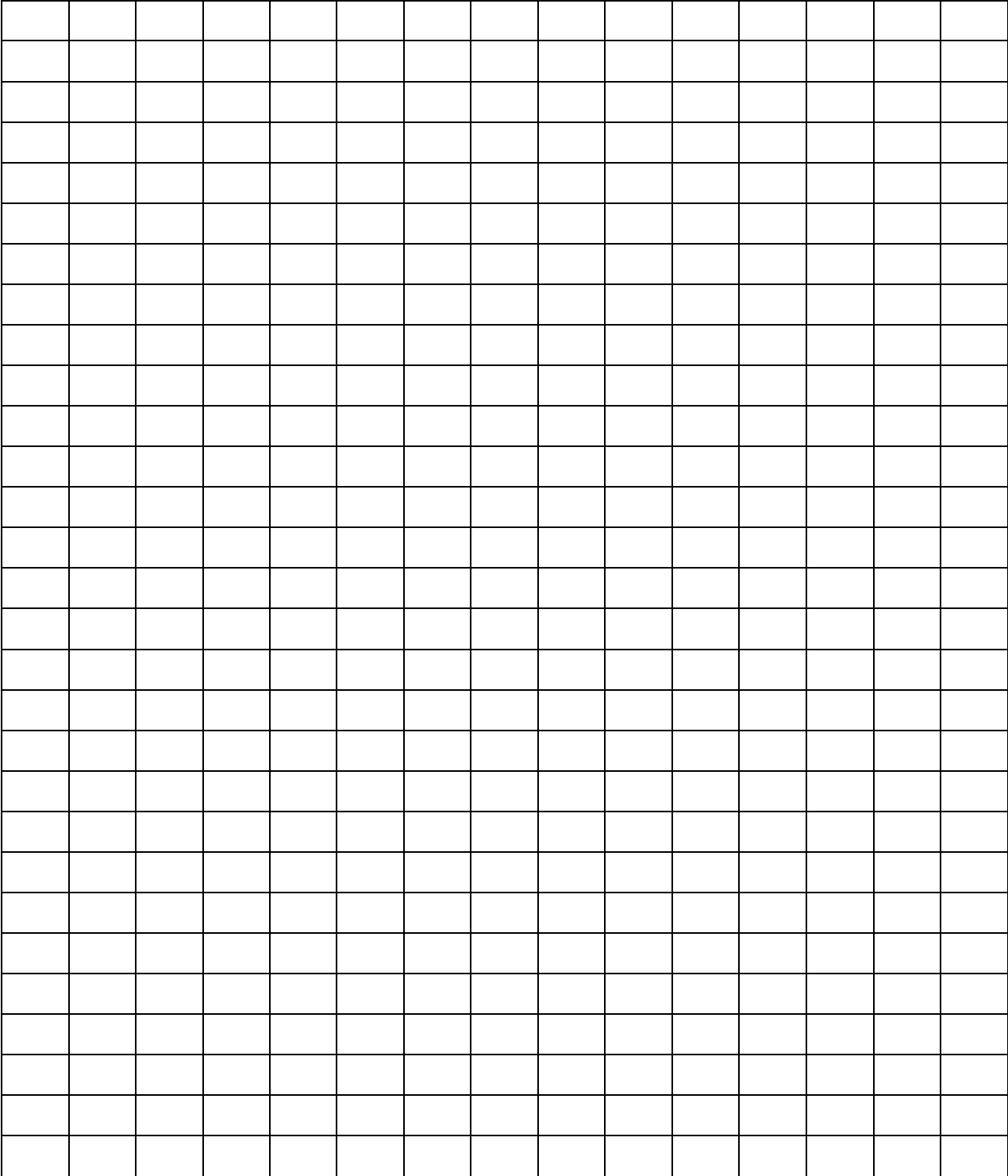

Table of Contents

EarthLinked® Dealer Information 2

User Benefits 5

How it Works

- Heating 5
- Cooling 5
- Water Heating..... 5

Comfort Control..... 6

System Components and Maintenance

- General 7
- Compressor Unit..... 7
- Air Handler/Cased Coil..... 9
- Hydronic Water Module..... 10
- Desuperheater Water Heating 11
- Auxiliary Cooling Module..... 12
- Earth Loop Protection System 13
- Storage Water Heater 14

Energy Savings Tips 16

Limited Warranty Coverage..... 17

Preventive Maintenance & Service 20



WARNING!

Your EarthLinked® Heating and Cooling System has been designed and manufactured for your safety and is certified to ETL safety standards. Only EarthLinked Technologies approved service technicians should install, service, repair or adjust this heating and cooling equipment.

Observe precautions in the literature, labels and tags attached to the equipment components, and any other safety precautions or local safety codes that may apply.

Electrical shock from this system may cause personal injury or death!

User Benefits

The EarthLinked® Heating and Cooling System has been engineered to provide many years of exceptional comfort and economy while being environmentally friendly. Some of the benefits are:

Comfort: Because EarthLinked® systems draw heat from the earth, which is a relatively constant temperature, you'll enjoy warmer air being delivered in the heating season. In cooling mode, EarthLinked® Systems remove more moisture than ordinary air conditioners, providing you with cool, dry air for greater summertime comfort.

Energy Savings: EarthLinked® Systems provide energy savings from 30% to 70% over other ordinary heating and cooling systems.

Cost Effective: The high energy efficiencies realized in heating and cooling operation result in year 'round energy savings that more than offsets the investment in an EarthLinked® System.

Quality: Since 1980, EarthLinked® has designed heating and cooling systems to the highest engineering standards and uses on the best quality component parts, in a meticulous manufacturing process.

Environmentally Friendly: EarthLinked® Systems reduce power consumption to a fraction of power consumed by ordinary electric heating and cooling systems, and generate no harmful greenhouse gases, unlike gas and oil fired equipment. The high efficiencies of EarthLinked® Systems also reduce the need for more electric power generation.

How It Works

Heating:

EarthLinked® Systems utilize the naturally occurring heat in the earth to provide heat indoors in the winter time. The system circulates refrigerant in sealed copper tubes through the earth loop to transfer heat from the earth. In the compressor unit, the refrigerant is compressed and heated to a higher temperature, and then delivered to an indoor coil where the heat is transferred to warm the intended space. Heat can be delivered by a fan blowing air from the room over a coil containing heated refrigerant, such as in an air handler or a cased coil; or the heated refrigerant can heat water, in a hydronic water module, and then be distributed through a tubing network to warm floors. After delivering heat, the refrigerant is re-circulated through the earth loop to transfer more heat from the ground to the compressor unit.

Cooling:

In cooling mode, the refrigerant flow is reversed, and the compressor increases the pressure and temperature of the refrigerant, propelling it through sealed earth loops where heat is transferred from the refrigerant into the cooler surrounding earth. As the heat is transferred from the refrigerant to the earth, the refrigerant cools and condenses into a liquid. The refrigerant passes through an expansion device, which lowers the refrigerant pressure and temperature on its way back to the indoor coil. Inside the indoor coil, the liquid refrigerant once again transfers heat from the room air passing over the coil surface, cooling and dehumidifying the room air while heating the refrigerant to a warm vapor, which is then returned to the compressor, to repeat the cycle.

Water Heating:

EarthLinked® Heating and Cooling Systems can augment residential water heating requirements by utilizing a desuperheater which, in the cooling mode, provides "free" heated water by capturing the wasted heat from the refrigerant. This system augments the hot water generated by the water heater. The desuperheater system is available as an integral part of the SD Series compressor unit, or as a Kit for field installation.

EarthLinked® also provides a dedicated water heating system through the use of a Domestic Water Module combined with a compressor unit and storage tank. The system provides hot water year 'round with power savings similar to that of a space heating and cooling system.

Comfort Control

Although thermostats vary widely in appearance, they all perform the same basic function: to control the operation of your EarthLinked® Heating and Cooling system and maximize year 'round comfort and economy.

Operating instructions are provided by the thermostat manufacturer for each thermostat. Familiarize yourself with its proper operation to realize the maximum comfort with minimum energy consumption.

Fan Operation

Auto: With the thermostat fan switch set to "AUTO", the indoor fan will run only when the compressor unit is operating in heating or cooling mode. This position will provide the lowest operating cost.

On: If the fan switch is set to "ON", the indoor fan will run continuously. This provides continuous air filtering and more even temperature distribution throughout the house.

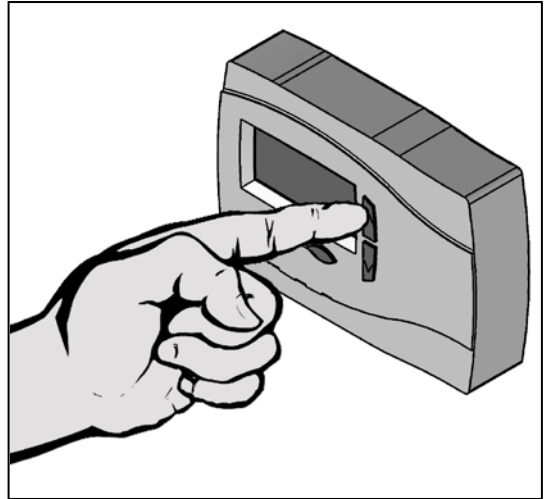

Heating Cycle

If the comfort control switch is in the "HEAT" position, the system will start when the indoor temperature drops below the temperature selected on the thermostat. The heating system will operate and the indoor fan will circulate warm air (or circulate warm hydronic water). When the room temperature rises to the temperature selected, the system will shut off.

Cooling Cycle

With the comfort control switch in the "COOL" position, the system will start when the indoor temperature rises above the temperature selected on the temperature adjustment setting. The cooling system will operate and the indoor fan will circulate cool, dehumidified air. When the room temperature drops to the temperature setting selected, the system will shut off.

Thermostat Maintenance

- Check your thermostat once a month to see that, as appropriate, there are no fault signals displayed or the Emergency Heat is not activated.
- To clean a thermostat, wipe the surface with a damp cloth. Never spray cleaning solution directly onto the thermostat.
- Move lamps and other heat generating appliances (radios, TVs, etc.) away from the thermostat to enable the thermostat to read the true surrounding air temperature.

System Components and Maintenance

General

In order to ensure peak performance, your system must be properly maintained.

Earthlinked Technologies strongly recommends annual inspection and preventive maintenance of this system by an ETI authorized service technician.

The user should check and maintain the items in the following schedule. The details for maintaining each item follow the maintenance schedule.

Every Month

- Air Filter
- Water Filtration System

Every 6 Months

- Condensate drains – compressor unit and air handler

Every 12 Months

- Storage Water Heater/Tank Flush
- T&P Valve
- Earth Loop Protection System

Other

- Superchlorination

Compressor Unit

Power Failure:

When accidents, wind storms, etc. disrupt electrical power supply to your house, turn the thermostat “OFF”. Turn thermostat “ON” only after power has been reinstated and after determining that there is no visible damage to the compressor unit or other system components.

Preventive Maintenance:

It is strongly recommended that regular yearly preventive maintenance be performed on the EarthLinked® compressor unit and all other system components, by an EarthLinked® trained and authorized dealer. The dealer can ensure your maintenance program meets the conditions of the Limited Warranty and that efficiency of the equipment is maintained. For preventive maintenance of the SCW series unit brazed plate heat exchanger, see the Hydronic Water Modules maintenance section.

Service Clearance:

For maintenance and service access, be sure to maintain a clearance of 3 feet in front and on top of the compressor unit and a clearance of 1 foot on each side of the compressor unit.

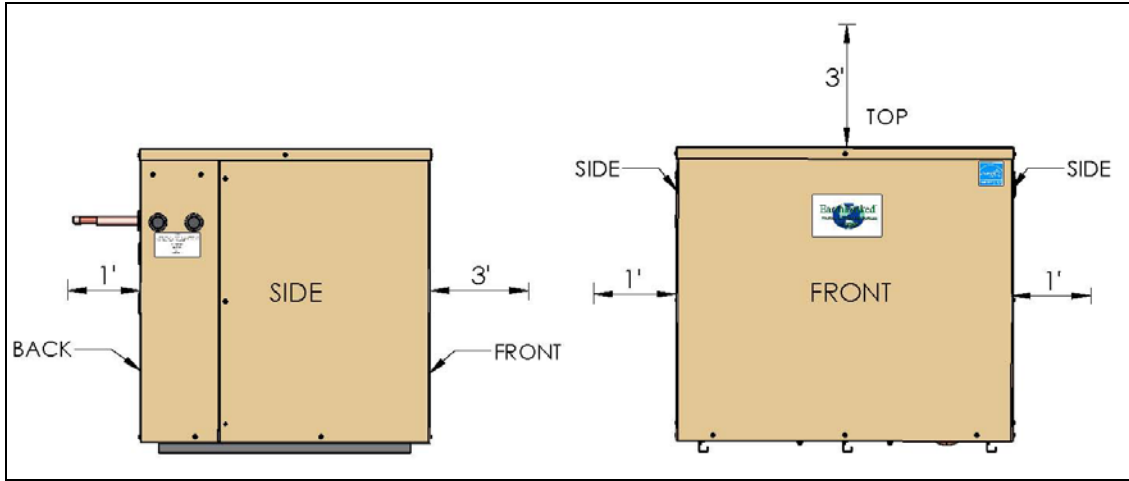

Condensate:

For indoor compressor unit installation, check the compressor unit at the back of the cabinet twice a year to ensure the condensate pan is collecting and draining condensate that may drip from the refrigerant lines entering the cabinet.

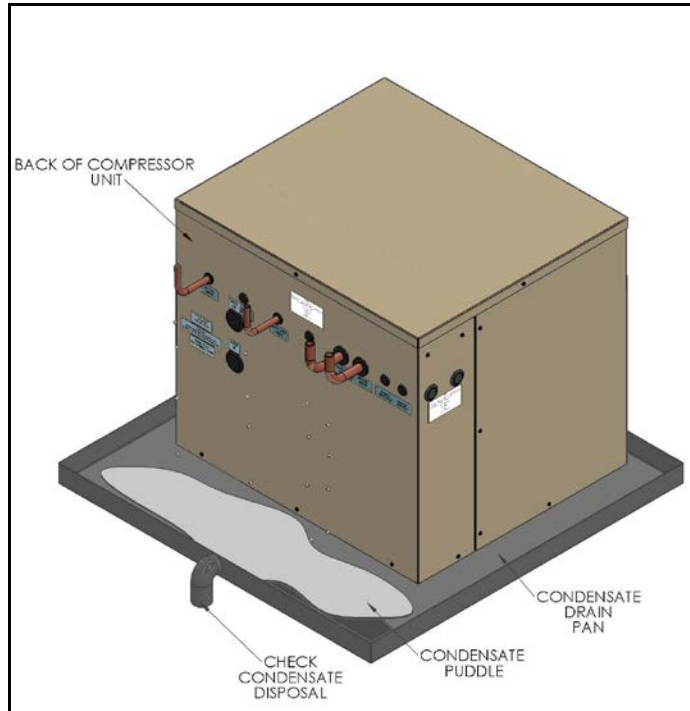

Sound:

Check the compressor unit twice a year for anything appearing or sounding unusual.

System Components and Maintenance

Air Handler/Cased Coil

Power Failure

When accidents, wind storms, etc. disrupt electrical power supply to your house, turn the thermostat "OFF". Turn thermostat "ON" only after power has been reinstated and after determining that there is no visible damage to the air handler, cased coil or other system components.

Service Clearance

A minimum of 30 inches clearance is to be maintained in front of the air handler or cased coil to ensure access for servicing.

Air Filter

Disposable air filters should be replaced every month. Replace with the same size filter.

Cleanable air filters should be cleaned every month, or as described in the filter manufacturer's instructions.

Condensate Drain Pan

During the cooling season, check the condensate drain pan to ensure that condensate (water condensed on the cooling coil) is flowing freely from the primary drain, but not from the secondary drain as shown below. If condensate ever flows from the secondary drain the unit should be shut off and the condensate drains cleaned by an ETI authorized service technician to ensure a free flowing primary drain.

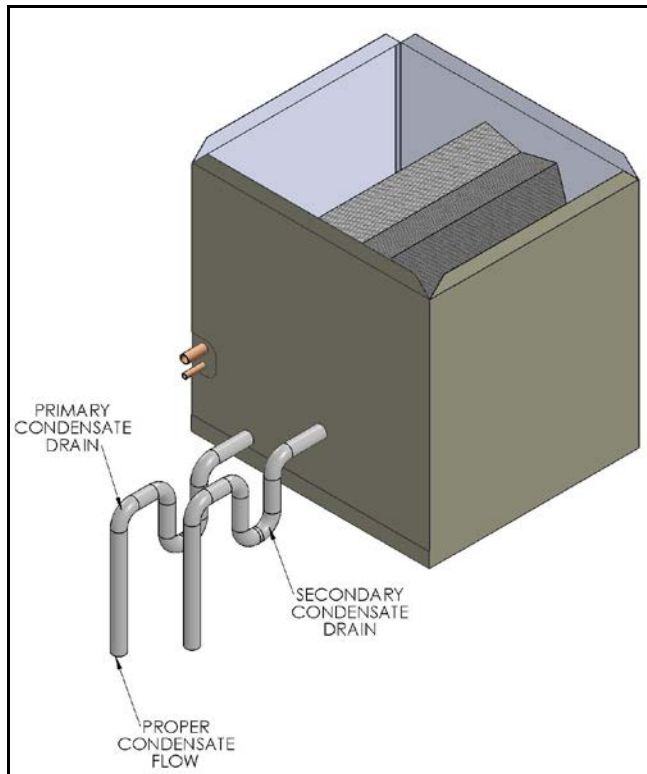

System Components and Maintenance

Hydronic Water Module

Power Failure:

When accidents, wind storms, etc. disrupt electrical power supply to your house, turn the thermostat “OFF”. Turn thermostat “ON” only after power has been reinstated and after determining that there is no visible damage to the hydronic water module or other system components.

Service Clearance:

A minimum of 30 inches clearance is to be maintained in front of the hydronic water module to ensure access for servicing.

Freeze Protection:

If you live in an area where freezing temperatures occur during the winter season, check with your EarthLinked® dealer to ensure that your hydronic system is freeze protected with an appropriate antifreeze solution.

Brazed Plate Heat Exchanger:

The hydronic water module and the SCW Series compressor units contain a brazed plate heat exchanger that requires yearly preventive maintenance performed by an EarthLinked® authorized service technician.

If it is determined that water side of the brazed plate heat exchanger requires superchlorination flushing, the following authorized procedure is implemented by the service technician:

When the water system undergoes a “superchlorination” or “shock chlorination” flushing process, the compressor unit or module must be isolated, so that superchlorinated water does not enter the compressor unit or module. **Failure to isolate the compressor unit or module will damage the heat exchanger and circulating pump, causing system failure. Allowing highly chlorinated water to enter the compressor unit or module will nullify the EarthLinked® Limited Warranty.**

- Prior to conducting the superchlorination procedure, turn OFF the electric power to the system.
- Close the isolation valves nearest the compressor unit or module.
- Conduct the superchlorination flushing process on the water system.
- Completely flush the water system with water that does not exceed the chlorine level consistent with municipal water purification standards.
- Open the isolation valves nearest the compressor unit or module and purge system of air.
- Turn ON the electric power to the system and initiate normal operation.

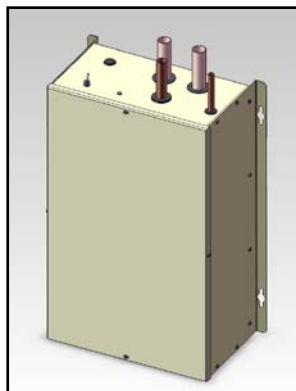

System Components and Maintenance

Desuperheater Water Heating

Power Failure:

When accidents, wind storms, etc. disrupt electrical power supply to your house, turn the thermostat "OFF". Turn thermostat "ON" only after power has been reinstated and after determining that there is no visible damage to the Desuperheater or other system components.

Service Clearance:

A minimum of 30 inches clearance is to be maintained in front of the Desuperheater to ensure access for servicing.

Freeze Protection:

If you live in an area where freezing temperatures occur during the winter season, the Desuperheater and associated water lines should be located in an area where the surrounding temperature does not drop below 40°F. If temperature drops below 40°F, check with your EarthLinked® dealer about relocating the Desuperheater.

Storage Water Heater

For information related to maintenance of storage water heaters, water filters or water strainers, see the maintenance section of Storage Water Heaters.

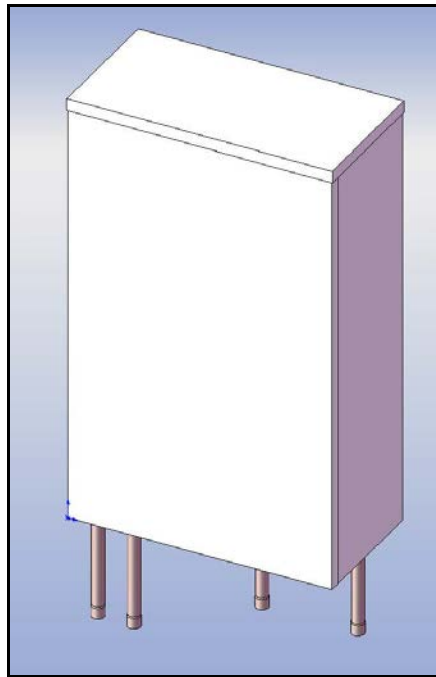

System Components and Maintenance

Auxiliary Cooling Model

Power Failure:

When accidents, wind storms, etc. disrupt electrical power supply to the you house, turn the thermostat “OFF”. Turn thermostat “ON” only after power has been reinstated and after determining that there is no visible damage to the Auxiliary Cooling Module or other system components.

Service Clearance:

The minimum clearances must be maintained should any yard improvements be made around the Auxiliary Cooling Module. The requirement is a clearance of 48 inches on top 24 inches on all sides.

Coil Care:

Keep the Auxiliary Cooling Module free of foliage, grass clippings, leaves, paper and any other material that could restrict the proper air flow in and out of the unit. If the coil becomes excessively dirty, turn the main disconnect switch to “OFF” and wash the coil with your garden hose, spraying water from the top of the unit in a downward direction over the coil surface. Avoid getting water into the fan motor and control box.

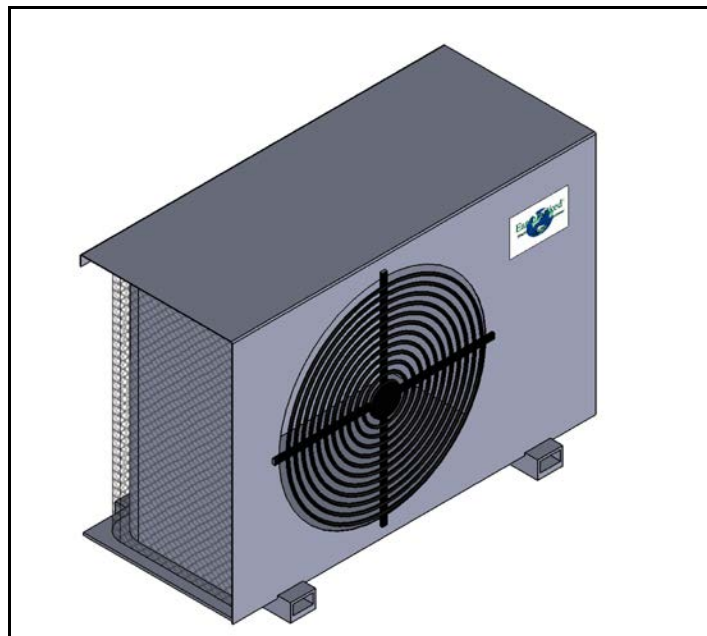

System Components and Maintenance

Earth Loops & Earth Loop Protection System

Power Failure:

When accidents, wind storms, etc. disrupt electrical power supply to your house, turn the thermostat “OFF”. Turn thermostat “ON” only after power has been reinstated and after determining that there is no visible damage to system components.

Service Clearance:

Your EarthLinked® dealer can provide you with a dimensioned plan view of the earth loops installed with your EarthLinked® Heating and Cooling System. Any improvements made to the area surrounding this earth loop field, must have the following clearance to avoid any impact on your system’s performance:

- 50 feet clearance from any water well, septic system or collection basin of de-icing salts or barnyard runoff
- One half the branch extremities of a fully grown tree or shrub.
- For earth loop fields with a Corrosion Protection System, there should be (1) no underground metal installed within 20 feet of the anode and (2) no underground metal installed between the anode and the earth loop field.

Earth Loop Protection System:

The EarthLinked® System has an Earth Loop Protection System with the control located inside the compressor unit.

If the control emits an audible signal, the system requires service.



IMPORTANT!

DO NOT TROUBLESHOOT! CALL YOUR EARTHLINKED® DEALER TO SERVICE THE EARTH LOOP PROTECTION SYSTEM.

System Components and Maintenance

Storage Water Heater

The following applies to installations involving the EarthLinked® SD compressor units and field applied EarthLinked® desuperheaters installed conjunction with EarthLinked® Series GSTE storage water heaters or Non-ETI electric storage water heaters.

Power Failure:

When accidents, wind storms, etc. disrupt electrical power supply to your house, turn the thermostat “OFF”. Turn thermostat “ON” only after power has been reinstated and after determining that there is not visible damage to the storage water heater or other system components.

Service Clearance:

A minimum of 30 inches clearance is to be maintained in front of storage water heater to ensure access for servicing.

Freeze Protection:

If you live in an area where freezing temperatures occur during the winter season, ensure that the air temperature is maintained at the temperature above 40°F around the storage water heater and associated water piping.

Water Filtration System:

If your water system has a water filtration system supplying the SD compressor, desuperheater or electric water heater, check the water system filter cartridge every month and, as appropriate, renew it by cleaning or replacing the filter cartridge as directed by the water filter manufacturer.

Guidelines are as follows:

- Turn OFF electrical power to the system
- Close the isolation valves on each side of filter and relieve the water pressure at the filter housing
- Remove the filter bowl and clean or replace the cartridge, per the manufacturer’s instructions
- Replace the filter bowl and gradually open the upstream isolation valve. Check for leaks
- Purge the system of air, open the downstream isolation valve, restore electric power to the system and operate normally

Storage Water Heater Flush:

Every 12 months the storage water heater should be flushed of residue as follows:

- Turn OFF electric power to the system.
- Close the isolation valves between the compressor unit or module and the storage water heater.
- Close the cold water supply isolation valve to the storage water heater.
- Open a faucet downstream of the hot water outlet on the storage water heater.
- After connecting the storage water heater drain valve to a drain hose, open the drain valve and drain the entire tank of water to an open drain.
- Close tank drain valve.

- Open the cold water supply isolation valve and fill the storage water heater with clean water until it is approximately 25% full.
- Turn off the main cold water supply isolation valve, open the storage water heater drain valve, and observe the water coming out of the drain valve going into the drain.
- Continue to flush the storage water heater as noted above until the water coming out the drain valve is clear and free of sediment.
- Close the drain valve and the faucet.
- Open the cold water supply isolation valve and fill the storage water heater and piping system with water.
- Open the isolation valves between the compressor unit or module and the storage water heater and purge air from system.
- Turn ON electric power to the system and initiate normal system operation.

Storage Water Heater T & P Valve Check:

Every 12 months the storage water heater T & P valve should be checked for proper operation as follows:

- Turn OFF electric power to the system.
- Attach a drain hose to the valve, with water discharge directed to an open drain.
- Lift the level at the end of the valve several times.
- The valve should operate freely and return to its original position properly.
- If water does not flow out of valve, close cold water supply isolation valve to the system and close isolation valves between compressor unit or module and storage water heater, and drain tank water level to below the T&P valve.
- Remove valve and inspect for corrosion or obstructions.
- Replace with new valve if necessary. DO NOT REPAIR AND INSTALL THE FAULTY VALVE.
- Open the isolation valves between the compressor unit or module and the storage water heater, and open the cold water supply isolation valve to fill the system. Purge air from system.
- Turn ON electric power to the system and initiate normal system operation.

Energy Savings Tips

- **Energy Star:** If you have an EarthLinked® Heating and Cooling System comprised of a compressor unit and matched with an EarthLinked® Air Handler or Cased Coil, you have already started saving energy, because you have an Energy Star rated system. The Energy Star program, sponsored by the U.S. Department of Energy and Environmental Protection Agency, is a program designed to help homeowners protect the environment using superior energy efficient products.
- **Thermostat:** Adjust your thermostat to a comfortable setting and leave it there. Don't be a "thermostat juggler". Moving your thermostat setting will not make your system heat or cool and faster.
- **Air Circulation:** Placing furniture, rugs, etc. in such a way that they interfere with air vents will make your system work harder to achieve the desired level of comfort. This requires more energy and increases you electric bill.
- **Lamps and Appliances:** Locate lamps and other heat producing appliances (radios, TVs, heaters, etc.) away from the thermostat. If they are close to the thermostat, the heat from these items will give your thermostat "false information" about the temperature in the room.
- **Ductwork:** As part of yearly maintenance, be sure your EarthLinked® dealer checks the ductwork in your house for leakage and insulation. Having sealed, insulated ductwork ensures that you are delivering conditioned air to the intended rooms.
- **Maintenance:** It is strongly recommended that regular yearly preventive maintenance be performed on the EarthLinked® compressor unit and other system components be an EarthLinked® trained and approved dealer. The dealer can ensure your maintenance program meets the conditions of the Limited Warranty and that efficiency of the equipment is maintained.

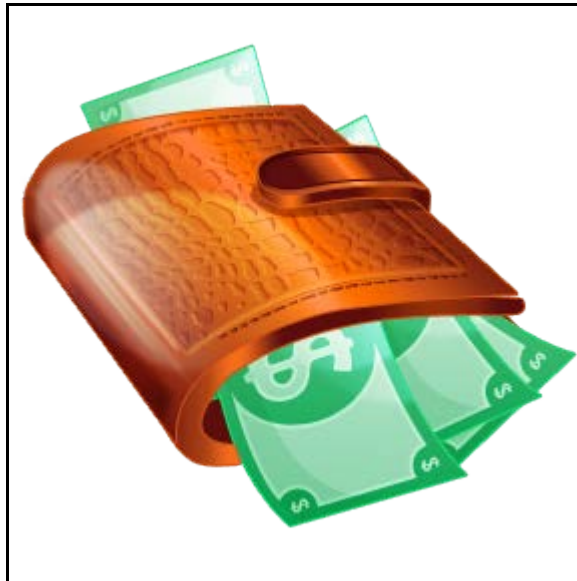

Limited Warranty Coverage

Earthlinked Technologies, Inc.'s (ETI) limited warranty provides coverage for all EarthLinked® System product parts. A part is any factory-installed part within an ETI product.

Upon a failure of a part during the warranty period, ETI will provide a replacement or repaired part to the servicing dealer. In addition, the servicing dealer will be paid an allowance in the form of a credit to the dealer's account on parts that are provided by ETI. All freight (return to and delivery from ETI) charges are the responsibility of the servicing dealer. The amount of the allowance shall be in accordance with the current *In-Warranty Allowance of EarthLinked® Heat Pump Products and DIRECT AXXESS® Earth Loops, LIT-66*. The allowance is designed to reduce the cost of service. However, it may not cover the entire labor fee charged by the servicing dealer.

ETI may not credit the dealer's account for claimed allowances if the appropriate warranty registration is not on file at ETI within 90 days after the product is shipped from ETI.

ETI shall not be liable for any defect, unsatisfactory performance, damage or loss, whether direct or consequential, relative to the design, manufacture, construction, application or installation of field-specified products or parts.

A copy of the Earthlinked Technologies, Inc. Limited Warranty is on the next page.



EARTHLINKED
TECHNOLOGIES

LIMITED WARRANTY

FOR S-SERIES 410A EARTHLINKED® HEAT PUMP PRODUCTS WITH FACTORY-INSTALLED EPS AND SURE-START AND DIRECT AXCESS® EARTH LOOPS

EarthLinked Technologies, Inc (ETI) hereby warrants to the consumer that the S-Series 410A EarthLinked® Heat Pump Products with factory-installed EPS and Sure-Start for units purchased on or after August 1, 2014, required and optional, and DIRECT AXCESS® Earth Loops are free from defects in materials and workmanship, and at its discretion, will replace or repair product parts, and reimburse labor costs in accordance with the terms of this Limited Warranty. The terms of this warranty are effective from the date of installation and apply only to products purchased and installed within the **USA and Canada**. **The installation and all subsequent service and maintenance must be done by an ETI authorized installer in accordance with the ETI manuals, in effect at the time of installation, service or maintenance, or the warranty will be void.** All transportation, service labor, diagnostic calls and excavation, backfilling and drilling expenses other than those specifically allowed by this Warranty are excluded.

Ten-Year Parts & Five-Year Labor for Specified Product Parts and Earth Loop Protection System: If a specified EarthLinked® compressor unit part (defined as the compressor, liquid flow control, active charge control, oil return, 3 and 4 way reversing valves, heat exchanger) or HVAC product part (defined as the air handler or cased coil heat exchanger, hydronic water module heat exchanger, domestic water module heat exchanger, desuperheater heat exchanger, auxiliary cooling module heat exchanger and EarthLinked® Earth Loop Protection System) fails within ten (10) years due to a defect in manufacture or ETI's fabrication of that part, ETI will provide the replacement or repaired part to the installer. The replacement or repaired part will be warranted for the remainder of the ten year period. If ETI provides the replacement or repaired part for a failure within five years of installation due to a defect in manufacture or ETI's fabrication, ETI will also provide for the reimbursement (**in the form of credit to the claimant's account**) of labor costs to the installer, as specified in the ETI In-Warranty Allowance Schedule in effect at the time of system installation.

Two-Year Parts & Labor for HVAC Components: If any other EarthLinked® Heat Pump product part (defined as all other compressor unit and HVAC product parts and the thermostat) fails within two (2) years due to a defect in manufacture or ETI's fabrication of that HVAC part, ETI will provide the replacement or repaired part to the installer. The replacement or repaired part will be warranted for the remainder of the two-year period. If ETI provides the replacement or repaired part for a failure within two years of installation due to a defect in manufacture or ETI's fabrication, ETI will also provide for the reimbursement (**in the form of credit to the claimant's account**) of labor costs to the installer, as specified in the ETI In-Warranty Allowance Schedule in effect at the time of system installation.

Twenty-Year Parts & Five-Year Labor for Earth Loops: If any DIRECT AXCESS® Earth Loop fails within twenty years due to a defect in material or workmanship in manufacture, ETI will provide the replacement or repaired part to the installer. The replacement or repaired part will be warranted for the remainder of the twenty-year period. If ETI provides the replacement or repaired part for a failure within five years of installation due to a defect in manufacture or ETI's fabrication, ETI will also provide for the reimbursement (**in the form of credit to the claimant's account**) of labor, excavation and backfill costs to the installer, as specified in the ETI In-Warranty Allowance Schedule in effect at the time of system installation.

Exclusions: This Warranty shall not apply to damaged or missing required product parts caused by transportation, improper or inadequate specification, sizing, installation, maintenance, service or alteration, any work done by unauthorized technicians, or acts of God; improper electrical supply, refrigerant or lubricant charge; use of products in a contaminated or corrosive atmosphere or fluid supply; operation of an ETI system at abnormal gas or liquid temperatures, pressures or flow rates; improper backfill, grouting or compaction of earth loops; use of the earth loops in a corrosive soil without ETI's Earth Loop Protection System, earth loops subjected to electrical currents, or field-specified earth loops without prior written approval from ETI. This Warranty does not apply to field-supplied products or parts installed in an ETI system. Field-supplied products must receive prior approval from ETI, otherwise the warranty will be deemed void.

THERE ARE NO WARRANTIES WHICH EXTEND BEYOND THE FACE HEREOF AND THIS LIMITED WARRANTY IS IN LIEU OF ANY AND ALL OTHER WARRANTIES AND LIABILITIES. THE FOREGOING STATES ETI'S ENTIRE AND EXCLUSIVE LIABILITY AND BUYER'S EXCLUSIVE AND SOLE REMEDY. ETI WILL IN NO EVENT BE LIABLE FOR ANY CONSEQUENTIAL, SPECIAL OR CONTINGENT DAMAGE OR EXPENSE ARISING DIRECTLY OR INDIRECTLY FROM ANY DEFECT IN ITS GOODS OR FROM THE USE THEREOF, NOR IS ANY OTHER PERSON AUTHORIZED TO ASSUME FOR ETI ANY SUCH LIABILITY.

IN NO EVENT, WHETHER AS A RESULT OF BREACH OF WARRANTY OR CONTRACT, NEGLIGENCE OR STRICT LIABILITY, SHALL ETI BE LIABLE FOR SPECIFIC, INCIDENTAL, OR CONSEQUENTIAL DAMAGES, INCLUDING, BUT NOT LIMITED TO, PROPERTY DAMAGE, LOSS OF USE OF THE EQUIPMENT OR ASSOCIATED EQUIPMENT, LOST REVENUES OR PROFITS, COST OF SUBSTITUTE EQUIPMENT OR COST OF FUEL OR ELECTRICITY. THE ABOVE LIMITATIONS SHALL INURE TO THE BENEFIT OF ETI'S SUPPLIERS, DEALERS, AGENTS AND SUBCONTRACTORS. THE ABOVE LIMITATION ON CONSEQUENTIAL DAMAGES SHALL NOT APPLY TO INJURIES TO PERSONS IN THE CASE OF CONSUMER GOODS.

SOME JURISDICTIONS DO NOT ALLOW THE EXCLUSION OR LIMITATION OR LIABILITY FOR CONSEQUENTIAL OR INCIDENTAL DAMAGES OR LIABILITY FOR STRICT LIABILITY IN TORT, SO THAT THE ABOVE EXCLUSIONS AND LIMITATIONS MAY NOT APPLY IN SUCH JURISDICTIONS.

ETI DOES NOT ASSUME, OR AUTHORIZE ANY OTHER PERSON TO ASSUME FOR ETI, ANY OTHER LIABILITY FOR AND/OR REGARDING THE SALE OF THIS PRODUCT AND/OR RELATED PRODUCT.

Preventive Maintenance & Service

It is strongly recommended that yearly preventive maintenance be performed on the EarthLinked® compressor unit and all other system components by an EarthLinked® trained and authorized dealer. The dealer can ensure your maintenance program meets the conditions of the Limited Warranty and that efficiency of the equipment is maintained.

Keep a record of your EarthLinked® System Maintenance and Service below:

DATE mm/dd/yy	DEALER	COMMENTS