

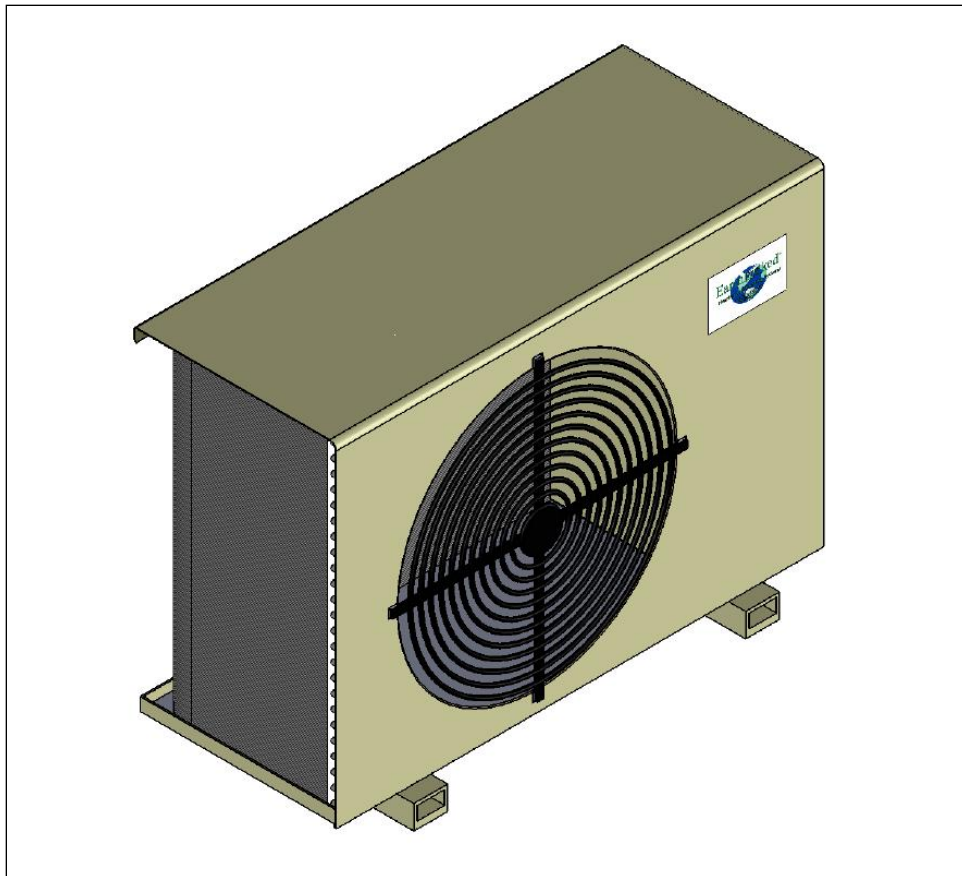

EARTHLINKED
TECHNOLOGIES

EarthLinked[®] Hybrid Cooling Module Models HCM-1836A and HCM-4272A *Installation Manual* **for R-22**

CONTENTS	PAGE
Pre-Installation	3
Installation	5
• Placement	5
• Refrigerant Connections	7
• Electrical and Start-Up	9
• Fan Speed Control	10



Disclaimer

The EarthLinked® Hybrid Cooling Module is sold as a system component part and must be properly sized and matched to the system compressor unit to provide the intended performance and safe operation of the system. This component must be installed and serviced by an ETI authorized technician. Installation and service must be made in accordance with the instructions set forth within this manual.

Failure to provide installation and service by an ETI authorized technician in a manner consistent with this manual will void the limited warranty coverage for the EarthLinked® system.

Earthlinked Technologies shall not be liable for any defect, unsatisfactory performance, damage or loss, whether direct or consequential, relative to the design, manufacture, construction, application or installation of other components in the EarthLinked® system.

Earthlinked Technologies, Inc.
4151 South Pipkin Road
Lakeland, Florida 33811
tel. 863-701-0096 • fax 863-701-7796
info@earthlinked.com • www.earthlinked.com

Pre-Installation

EarthLinked® compressor units that provide space cooling shall be equipped with an EarthLinked® Hybrid Cooling Module when (1) ambient outdoor temperatures have exceeded the outdoor summer design temperature conditions for at least 7 hours of continuous system run time, combined with (2) low thermal conductivity soils that do not effectively absorb and dissipate heat. Examples of such soils are light dry soil, dry sand, peat and organic soils, dry clay and hardpan.

This Hybrid Cooling Module is sold as a system component and must be properly matched with the compressor unit to provide the anticipated performance and safe operation of the system. The table below lists the properly matched EarthLinked® Hybrid Cooling Module models with EarthLinked® compressor unit models.

If the HCM is installed as a retrofit, the refrigerant charge in the existing system must be recovered before HCM installation. Use new refrigerant to recharge the system.

Application of the Hybrid Cooling Module (HCM) to EarthLinked® systems will require the use of two (2) field supplied Type ACR copper couplings to match the HCM with the line set vapor tube size. See the table below to determine the required coupling sizes.

Compressor Unit Model	Hybrid Cooling Module		Vapor Line Set Size, OD, in.
	Model HCM -	Connections OD, In.	R-22
-018	1836A	7/8	5/8
-024			3/4
-030			3/4
-036			3/4
-042	4272A	1-1/8	7/8
-048			7/8
-060			1-1/8
-072			1-1/8



WARNING

Before installing this Hybrid Cooling Module (HCM), be sure that all electrical power to the Earthlinked® system is “OFF”. Wear adequate protective clothing and practice all applicable safety precautions while installing this equipment. Failure to do so may result in equipment and/or property damage, personal injury or death.



WARNING

Inhalation of high concentrations of refrigerant gas vapor is harmful and may cause heart irregularities, unconsciousness or death. Vapor reduces oxygen available for breathing and is heavier than air. Decomposition products are hazardous. Liquid contact can cause frostbite. Avoid contact of liquid with eyes and prolonged skin exposure. Liquid and gas are under pressure. Deliberate inhalation of refrigerant gas is extremely dangerous. Asphyxiation can occur without warning due to lack of oxygen. Before working with a refrigerant, read the Materials Safety Data Sheet for that specific refrigerant.

The dimensions and data for the Hybrid Cooling Module is shown in Figure 1.

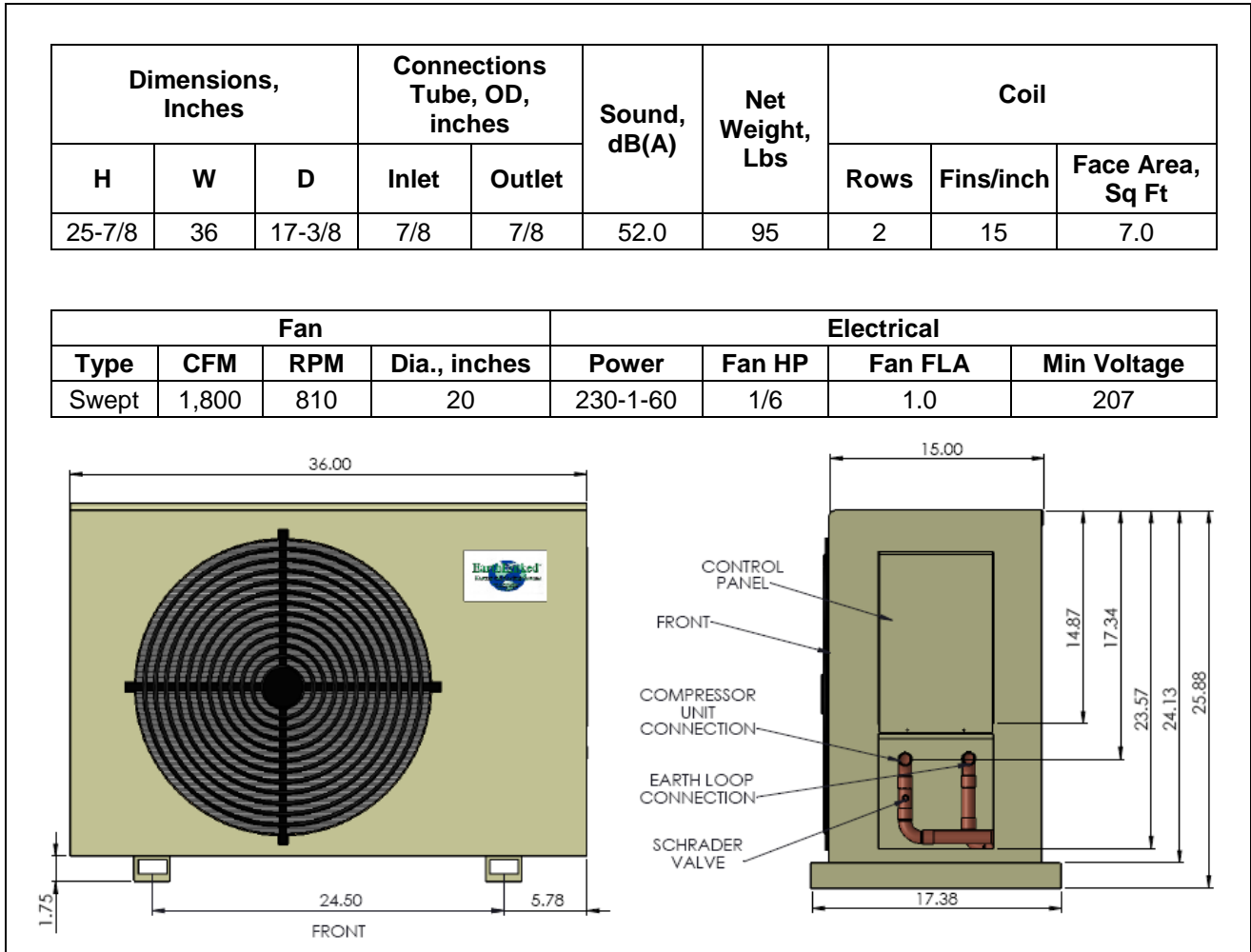

Figure 1. Hybrid Cooling Module Dimensions and Data

Installation – Hybrid Cooling Module Placement

The Hybrid Cooling Module unit is placed as shown in Figure 2 relative to other components in the EarthLinked® system. **The Hybrid Cooling Module is located outdoors and will be connected to the refrigerant line set (vapor tube) outside the building.**

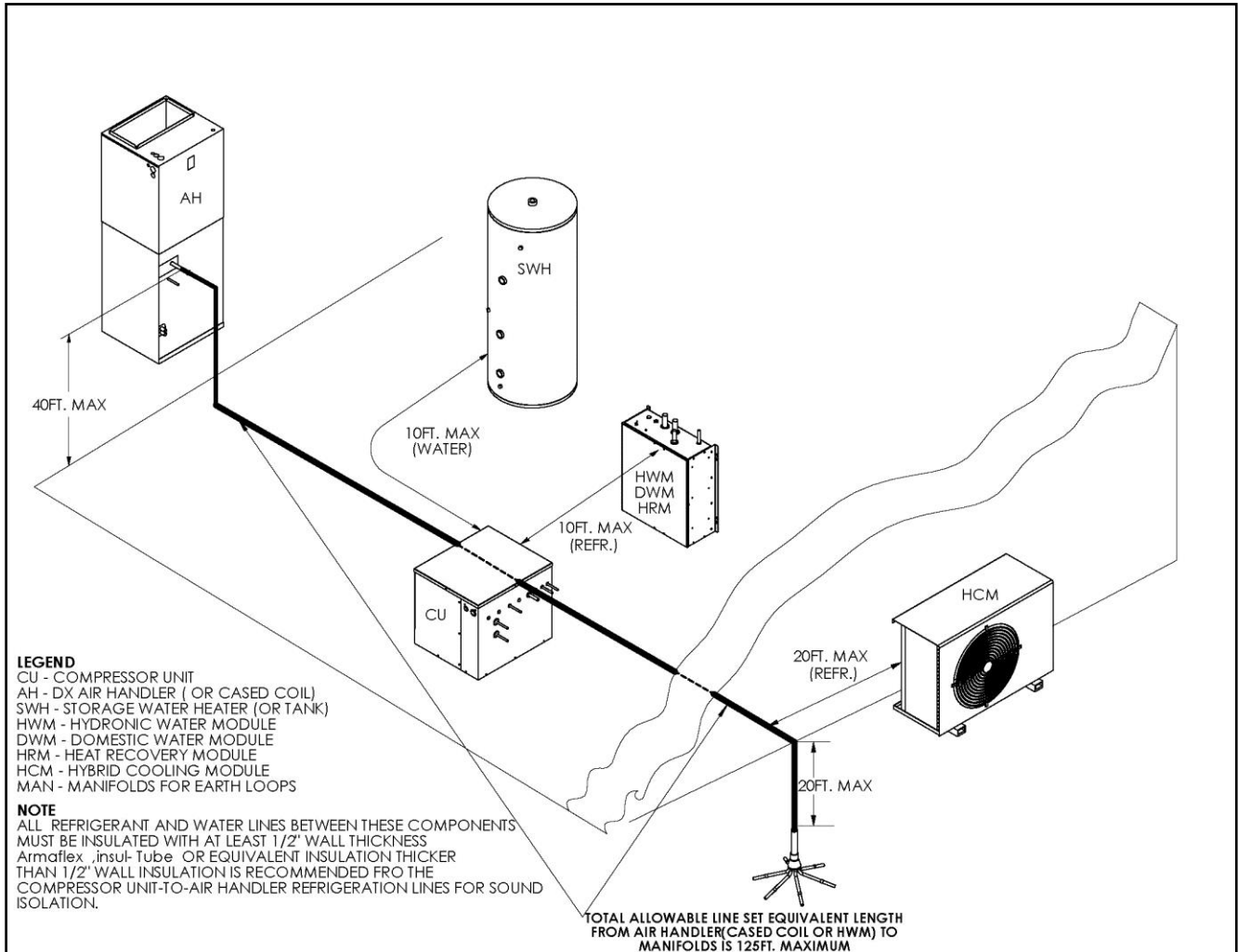

Figure 2. Hybrid Cooling Module Placement in EarthLinked® System

Location Requirements for the Hybrid Cooling Module:

1. Within 20 Feet of the earth loop line set. Minimize refrigerant line lengths.
2. No more than 20 feet higher than the earth loop manifolds.
3. With proper clearances around the unit:
 - 24 inches minimum on the two sides and back (coil side)
 - 36 inches minimum on the front (fan side)
4. Away from windows, patios, decks, etc., where unit operation sounds may disturb the occupants.

- On a solid, level mounting pad. The mounting pad should extend a minimum of 2 inches beyond the cabinet size of the Hybrid Cooling Module. **The minimum pad size is to be 22 inches by 46 inches.** The pad should NOT be in contact with or be an integral part of the building foundation. The following DiversiTech Pads (or their equivalent) are recommended. The standard pads are 2 inches thick. Local building codes may require a 3 inch thick pad.

<u>Model Number</u>	<u>Size, Inches</u>	<u>Comments</u>
Ultralite® UC2448-2	24 x 48 x 2	fiber-cement construction
Ultralite® UC2448-3	24 x 48 x 3	fiber-cement construction
Elite® EL3648-2	36 x 48 x 2	Plastic-drillable for securing unit
Elite® EL3648-3	36 x 48 x 3	Plastic-drillable for securing unit

- Where conditions or local codes require the Hybrid Cooling Module to be attached to a mounting pad or frame, tie down bolts should be used to fasten through the holes provided in the Hybrid Cooling Module feet.
- Elevate the Hybrid Cooling Module per local climate and code requirements to provide clearance above estimated snowfall level and ensure adequate water drainage of Hybrid Cooling Module. Use snow stand in areas where prolonged freezing temperatures are encountered.

Do NOT Locate the Hybrid Cooling Module:

- On brick, concrete blocks or unstable surfaces
- Near clothes dryer exhaust vents
- Near sleeping area or near windows
- Under eaves where water, snow or ice can fall directly in the unit
- Within clearance less than 2 Feet from a second unit
- Within the minimum distance the Hybrid Cooling Module can be installed from the property line, where local zoning ordinances apply.

Installation – Refrigerant Connections

The Hybrid Cooling Module has two refrigerant connections on the service side of the unit as shown in Figure 1. The connections are the same size as each other. Each connection is identified with a label saying “Compressor” or “Earth loops”. Check Figure 1 and the table on page 3 to determine coupling sizes to match the line set vapor tube size.



IMPORTANT!

The Hybrid Cooling Module has a factory charge of dry nitrogen at approximately 35psig. Relieve the nitrogen from the system by means of the Schrader valve located on the compressor unit connection shown in Figure 1.

The refrigerant connections have caps brazed on at the factory. They should be un-brazed at the time that tubing is to be connected to the Hybrid Cooling Module.

After locating the Hybrid Cooling Module as noted earlier, a trench 3 to 4 Feet deep is to be excavated running from the Hybrid Cooling Module to the earth loop line set. If the lines to and from the Hybrid Cooling Module are to be run parallel to and within 10 Feet of the building foundation or basement wall, both lines are to be insulated with ½” wall thickness Armaflex® or InsulTube® tubing insulation, cased within a PVC pipe. The PVC pipe must be a minimum of 3 Feet from the building foundation or wall. This is illustrated for a typical application in Figure 3.

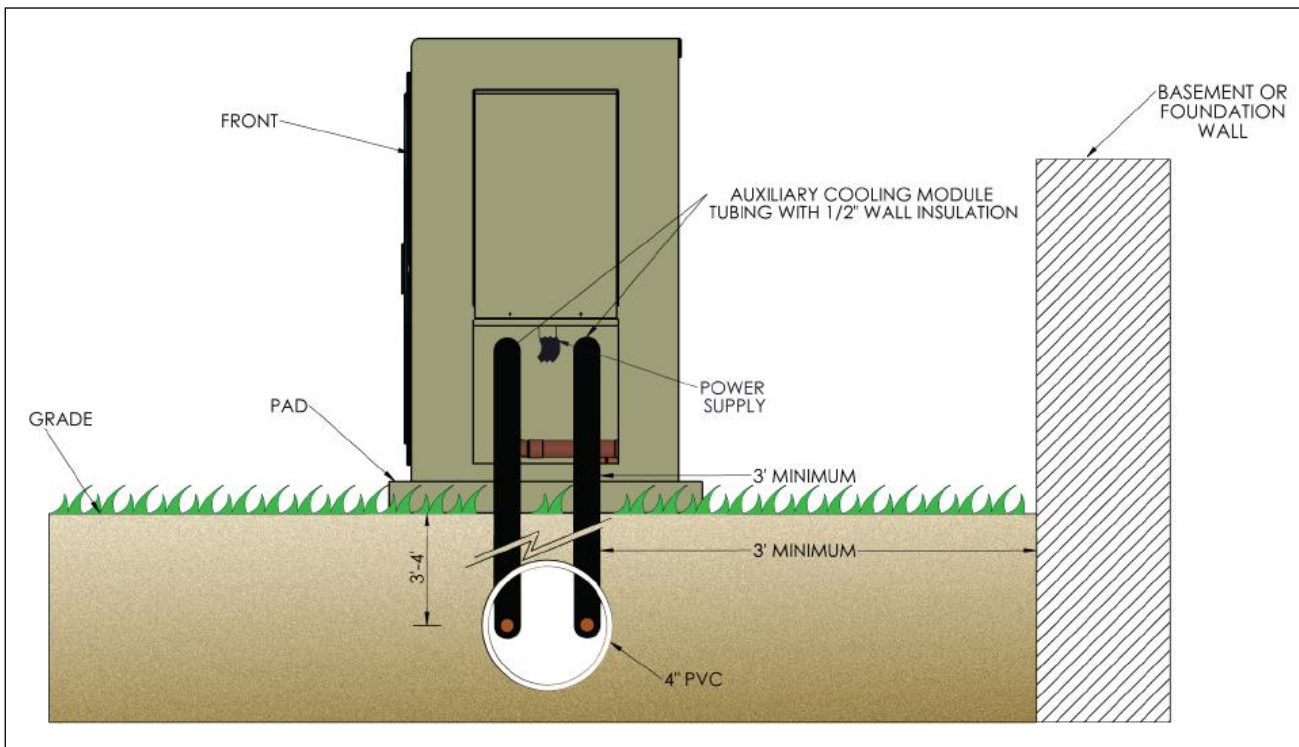

Figure 3. Hybrid Cooling Module Refrigerant Piping

A top view of typical Hybrid Cooling Module and line set vapor line connections are illustrated in Figure 4. For new installations of an EarthLinked system with an HCM, an alternate method to the one shown in Figure 4 is to run a single piece vapor line from the compressor unit to the HCM and another single piece vapor line from the HCM to the vapor manifold of the earth loop system.

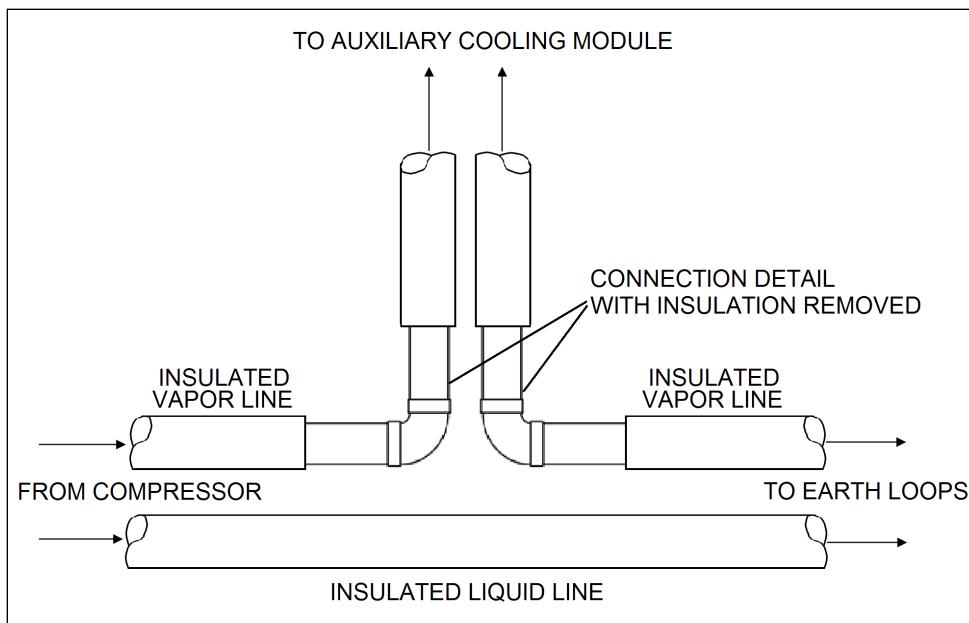

Figure 4. Top View of Line Set Connections

All refrigerant piping joints and connections in the EarthLinked® heating and cooling system, including the Hybrid Cooling Module, line sets and earth loop system are to be brazed with 15% silver content brazing alloy, utilizing the **NITROGEN BRAZING PROCESS**.



IMPORTANT!

NITROGEN BRAZING PROCESS

PURPOSE:

Utilize the **NITROGEN BRAZING PROCESS** on all brazed refrigerant piping connections. This process eliminates oxidation products from inside joint surfaces.

TECHNIQUE:

“Trickle” nitrogen gas at 1-2 psi pressure through the joint area being brazed to displace the oxygen. When oxygen has been displaced, **TURN THE NITROGEN OFF**.

CONSEQUENCES:

Failure to displace oxygen with nitrogen at the brazed joint will result in particulate matter being released into the system. The result is discoloration of refrigerant oil, contamination of the system and possible system failure.

Installation – Electrical and Start-Up



WARNING

BEFORE REMOVING ANY ACCESS PANELS AND INITIATING ANY PHASE OF THIS INSTALLATION MAKE SURE THAT POWER IS TURNED "OFF" TO ALL EARTHLINKED® AND FIELD SUPPLIED SYSTEM COMPONENTS. FAILURE TO DO SO COULD RESULT IN PROPERTY DAMAGE, SERIOUS INJURY OR DEATH.



WARNING

WEAR ADEQUATE PROTECTIVE CLOTHING AND PRACTICE ALL APPLICABLE SAFETY PRECAUTIONS WHILE INSTALLING THIS EQUIPMENT. FAILURE TO DO SO MAY RESULT IN EQUIPMENT AND/OR PROPERTY DAMAGE, PERSONAL INJURY OR DEATH.

1. After turning "OFF" power to all EarthLinked® and field supplied system components at the appropriate breakers **remove the Hybrid Cooling Module control box access panel.**
2. Connect appropriately sized line voltage wires and ground wire to the Hybrid Cooling Module, as shown in Figure 5.

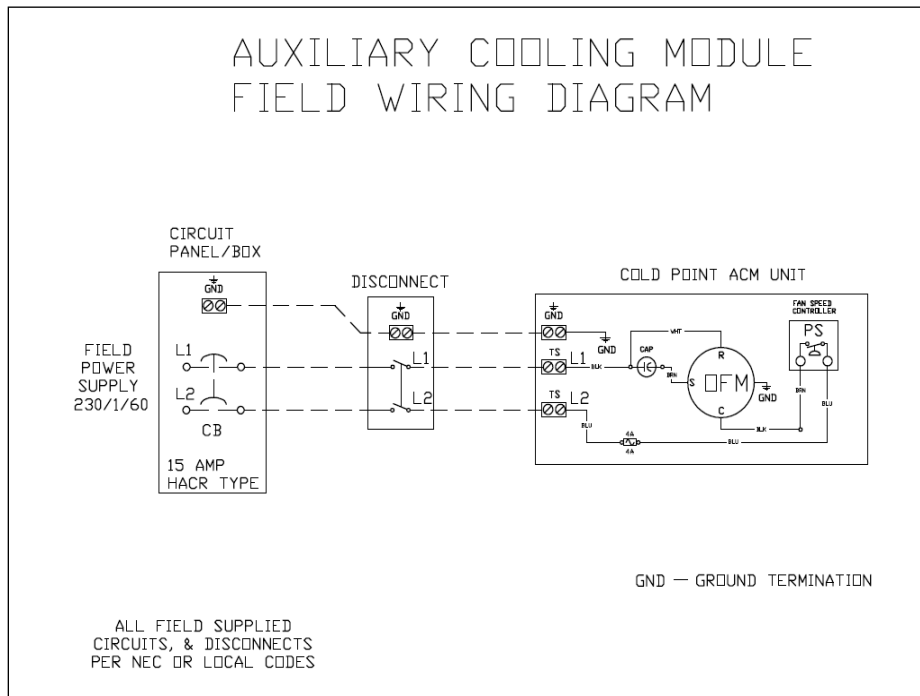

Figure 5. Hybrid Cooling Module Field Wiring



WARNING

The Hybrid Cooling Module cabinet must have an unbroken ground. The ground must be installed in accordance with applicable electrical codes. Failure to follow this warning can result in injury, fire or death.

3. The Hybrid Cooling Module contains a pressure actuated fan speed control that has been factory set for a pre-determined R-22 system condensing pressure.
4. **Check all wiring and electrical connections to ensure proper routing and good contact** before restoring electric power, evacuating and recharging system in accordance with the current EarthLinked® system installation manual.

Installation - Fan Speed Control

The Hybrid Cooling Module (HCM) is equipped with a variable fan speed control that varies the speed of the fan as a direct function of the system condensing pressure. **When the system is operating in cooling mode** and the compressor unit turns on, the Hybrid Cooling Module fan speed will increase as condensing pressure increases. The fan will reach full speed at the factory-set condensing pressure.

The system pressure setting and associated condensing temperature for full speed fan has been factory-set and is shown in Figure 6.

Factory Setting for Full Speed Fan		Field Adjustment Guide (per 1/4 Turn)		
Condensing Pressure, psig	Condensing Temperature, °F	Setting Screw Rotation	Condensing Pressure Change, psig	Condensing Temperature Change, °F
243	115	1/4 Turn	~12	~3

Figure 6. R-22 Condensing Pressure and Temperature Information

If it is necessary to adjust the full speed fan pressure setting in the field, the Hybrid Cooling Module pressure control may be adjusted by accessing it through the ACM control panel cover.



IMPORTANT!

Be sure that the Hybrid Cooling Module disconnect is OFF prior to removing the control panel cover.

With the control panel cover removed, the pressure control will appear as it does in the left view of Figure 7. After removing the sealing plug, the 5/64" Allen key is inserted into the setting screw to adjust the pressure level and associated condensing temperature for full speed fan operation. Figure 6 indicates **the change in full speed fan pressure and condensing temperature for each 1/4 turn of the setting screw.**

CLOCKWISE rotation of the setting screw **INCREASES** full speed fan pressure and condensing temperature.

COUNTER-CLOCKWISE rotation of the setting screw **REDUCES** full speed fan pressure and condensing temperature.

PRESSURE SETTING- FIELD ADJUSTMENTS

1. REMOVE SEALING PLUG
2. INSERT 5/64" ALLEN KEY INTO SETTING SCREW
- 3.a TURN SETTING SCREW CLOCKWISE TO INCREASE THE PRESSURE SETTING @12 PSIG PER 1/4 TURN
- 3.b TURN SETTING SCREW COUNTER-CLOCKWISE TO DECREASE THE PRESSURE SETTING @12 PSIG PER 1/4 TURN

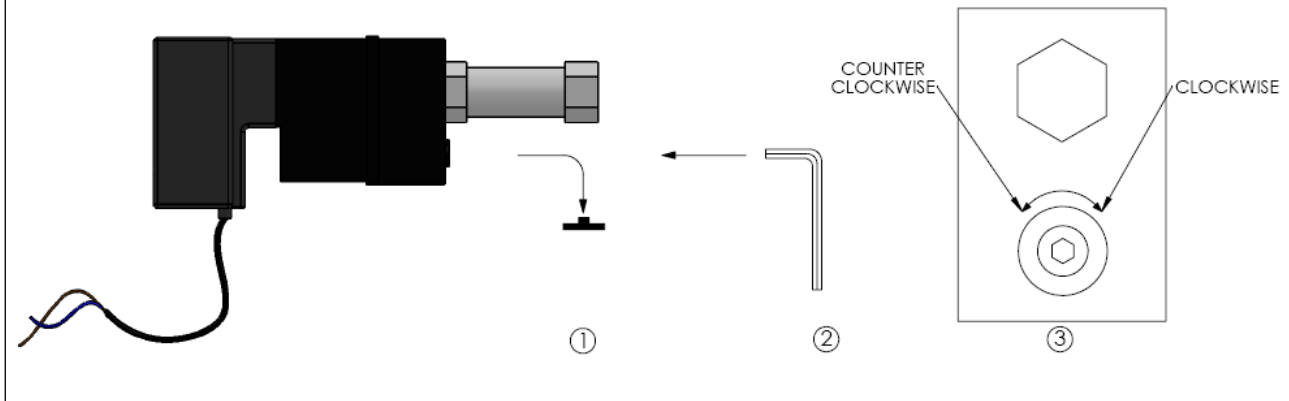

Figure 7. Field Adjustment Procedure

After adjustment has been made, install the sealing plug and replace and fasten the control panel cover prior to restoring power to the Hybrid Cooling Module.

The Hybrid Cooling Module does not operate in heating mode.